



APE CLAMP ATTACHMENT CATALOG AND OWNER'S MANUAL



800-248-8498

WWW.AMERICANPILEDRIVING.COM



SPECIFICATIONS



OPERATORS INFORMATION



MAINTENANCE AND TROUBLESHOOTING



REPLACEMENT PARTS AND BOM



REFERENCE / NOTES

This Quick Reference Guide will assist you in finding the information you're looking for.

A Table of Contents is included after the Foreword.

These precautions must always be followed to ensure personnel and equipment safety.



DANGER indicates a hazardous situation which, if not avoided, will result in death or serious injury.



WARNING indicates a hazardous situation which, if not avoided, could result in death or serious injury.



CAUTION indicates a hazardous situation where injury could occur but is unlikely to be serious or lead to death.

NOTICE

NOTICE indicates information that may help or guide you in the operation or service of the equipment.

READ THIS MANUAL THOROUGHLY BEFORE OPERATING AND / OR WORKING ON THE EQUIPMENT.

1. Only well-trained and experienced personnel should attempt to operate or maintain this equipment.
2. **NEVER** adjust, lubricate, and/or repair the unit when it is in operation or lifted above ground level.

3. **NEVER** remove, paint over, and/or cover warning or safety labels. If labels become damaged or unreadable, replace immediately.
4. All personnel should wear approved safety clothing including **HARD HATS, SAFETY SHOES, PROTECTION** when near this equipment.
5. Do **NOT** stand any closer to this equipment than necessary when it is in operation. Parts, dirt, and/or rocks may fall. **NEVER** stand under operating or elevated equipment. Keep eyes on equipment while it is running.
6. When maintaining and/or repairing the equipment, **NEVER** substitute parts not supplied or approved in writing by APE.

NOTICE

Do NOT weld or flame cut on this equipment.

7. Ensure that all lifting equipment, including cranes, wire rope, slings, hooks, shackles, etc., are properly sized for the worst caseloads anticipated during operations.
8. If there are any questions about weights, specifications, and/or performance of the unit, contact APE before handling and/or operating the equipment.
9. Check wire rope clips for tightness and wire ropes for wear daily.
10. Ensure that ground vibrations will not damage or collapse adjacent structures or excavations.
11. If abnormal equipment operation is observed, discontinue use immediately and correct the problem.

These precautions must always be followed to ensure personal and equipment safety.

NOTICE

A properly maintained fire extinguisher, suitable for oil fires, MUST be kept in the immediate vicinity of equipment operations.

12. Make sure that the drive and clamp switches are in NEUTRAL and the control panel is set to LOCAL before starting the power unit engine.
13. **NEVER** operate this equipment with hydraulic hoses that are damaged or kinked. Replace damaged hoses immediately.
14. Do **NOT** lift and/or support hydraulic hoses with wire rope slings.
15. **NEVER** attempt to connect or disconnect Quick Disconnects (QDs) when the power unit is running.
16. Do **NOT** pull on and/or attempt to move equipment with the hydraulic hoses.
17. Do **NOT** attempt to locate hydraulic leaks with your hands. High-pressure leaks can penetrate skin and cause severe damage, blood poisoning, and/or infection.
18. Do **NOT** attempt to repair leaks while the equipment is in operation.
19. Do **NOT** attempt to tighten and/or loosen fittings and/or hoses when the equipment is in operation.
20. When moving and/or transporting this equipment, make sure that the vehicle or vessel has enough capacity to handle the load. Make sure that the equipment is properly tied down.
21. When moving and/or transporting this equipment, be sure that the QD dust caps are tight and that the cap safety cables are in place. Be sure that all equipment parts are tight and/or properly secured before shipment. Unsecured parts may vibrate loose and fall during transport causing injury and/or property damage.
22. Rounded and/or damaged bolt heads and/or nuts should be replaced so that the proper torque values may be obtained. Proper torque values are necessary to prevent parts on this equipment, leads and/or crane booms from loosening and/or falling.
23. Do **NOT** place limbs, wires, or tools, etc., near clamp jaws while clamp could be energized.
24. Do **NOT** allow clothing, hoses, ropes, etc., to become entangled in, or pass between, clamp jaws.
25. Do **NOT** paint over or otherwise block grease-zerks.
26. Every 30 to 45 minutes of vibro operation, stop driving and relieve clamp pressure. Reclamp pile before resuming work.
27. Do not leave the clamp pressurized for periods of inactivity longer than 1 hour.

DANGER

*When operating in an enclosed area, exhaust fumes from the power unit should be piped outside. Continued breathing of exhaust fumes may prove **FATAL**.*

WARRANTY INFORMATION

Effective : _____

American Piledriving Equipment, Inc. (APE) warrants new products sold by it to be free from defects in materials or workmanship for a period of two (2) years after the date of delivery to the first user and subject to the following conditions:

- APE's obligation and liability under this WARRANTY is expressly limited to repairing or replacing, at APE's option, any parts which appear to APE upon inspection to have been defective in material or workmanship. Such parts shall be provided at no cost to the user, at the business establishment of APE or the authorized APE distributor of the product during regular working hours.
- This WARRANTY shall not apply to component parts or accessories of products not manufactured by APE, and which carry the warranty of the manufacturer thereof, or to normal maintenance (such as engine tune-up) or normal maintenance parts (such as filters).
- Replacement or repair parts installed in the product covered by this WARRANTY are warranted only for the remainder of the warranty as if such parts were original components of said product.
- APE makes no other warranty, expressed or implied, and makes no warranty of merchantability of fitness for any particular purpose.
- APE's obligations under this WARRANTY shall not include any transportation charges, costs of installation, duty, taxes or any other charges whatsoever, or any liability for direct, indirect, incidental, or consequential damage or delay.
- If requested by APE, products or parts for which a warranty claim is made are to be returned, transportation prepaid, to APE.

OIL MUST MEET ISO CLEANLINESS CODE 17/15/11.
OIL THAT DOES NOT MEET CLEANLINESS CODE
WILL **VOID** THE WARRANTY.

ANY IMPROPER USE, INCLUDING OPERATION
AFTER DISCOVERY OF DEFECTIVE OR WORN
PARTS, OPERATION BEYOND RATED CAPACITY,
SUBSTITUTION OF ANY PARTS WHATSOEVER,
USE OF PARTS NOT APPROVED BY APE OR ANY
ALTERATION OR REPAIR BY OTHERS IN SUCH A
MANNER AS, IN APE'S JUDGEENT, AFFECTS THE
PRODUCT MATERIALLY OR ADVERSELY, SHALL
VOID THIS WARRANTY.

ANY TYPE OF WELDING ON APE'S EQUIPMENT
WILL **VOID** THE WARRANTY UNLESS AUTHORIZED
IN WRITING BY APE

NO EMPLOYEE AUTHORIZED TO CHANGE THIS
WARRANT IN ANY WAY OR GRANT ANY OTHER
WARRANTY UNLESS SUCH CHANGE IS MADE IN
WRITNG AND SIGNED BY AN OFFICER OF APE,
INC.

This manual covers **APE Clamp Attachments** in selection, installation, maintenance, and use.

This manual was prepared to acquaint the owner, operator, and serviceman with the operation and maintenance of APE Clamps, and to aid in acquiring replacement parts. We strongly suggest that this manual be carefully studied before operating or undertaking any maintenance work on the units. It is not meant to be all inclusive as to content, and any questions and/or doubt should be directed to APE before proceeding with any operation or maintenance.

All information given in this manual is current and valid according to the information available at the time of publication. American Piledriving Equipment, Inc. reserves the rights to implement changes without prior notice.

Using this manual:

- Refer to the Table of Contents for the page location of applicable sections.
- All weights and measurements are in English and Metric units.
- Any revisions to this manual will appear on the Revision Record page at the back of this manual. The revisions themselves will be attached to the back of the manual and entitled ADDENDA with references back to the page in question in the original manual.
- Please visit www.americanpiledriving.com for further product data sheets and manuals.

Common Abbreviations:

APE = American Piledriving
Equipment

Vibro = Vibrator

QD = Quick Disconnect

mm. = Millimeters

lbs. = Pounds

psi. = Pounds per square inch

HCLW = High Collar Lock Washer

SHCS = Socket Head Cap Screw

BOM = Bill of Materials

cm. = Centimeters

in. = Inches

kip = Kilopound

kPa. = Kilopascal

Disclaimer:

This unit was tested before leaving our facility. To help provide years of trouble free usage, please review the following documentation and make sure to clean and flush the field piping before connecting to the Power Unit.

Refer to schematic diagrams and the BOM (Bill of Materials) on Pg. 46 for component part specifications and spare parts.

When calling APE, always inform your representative of the serial number to obtain quicker service.

Information provided in the Specifications chapter is not to be considered exact. Variations exist between different production series of the same unit. Contact APE with questions about any given model.

TABLE OF CONTENTS

Specifications	9	Replacement Parts/BOM	46
Clamp and Vibro Compatibility	9	Ordering Parts	46
APE Sheet Clamps.....	10	Hose and Fitting Replacement.....	47
Special Sheet Clamps	12	Bills of Materials.....	50
Wood / Concrete Clamps	14	Model 6 Removeable Clamp	50
Standard Caisson Beams	18	Model 6 and 9 Combined Gearbox and Clamp	52
Caisson Quad Beams	20	Model 20 Sheet Clamp.....	54
Caisson Clamps.....	22	Model 50 Sheet/Dunce Clamp	56
Other Clamp Accessories	23	Model 150 Sheet/Dunce Clamp	58
Small and Gearbox Incorporated Universal Clamps	24	Model 200 Sheet Clamp.....	60
Operators Information	26	Model 300 Sheet Clamp.....	62
Component Overview	26	Model 400 Sheet Clamp.....	64
Labels and Warnings	28	Model 126 J&M Sheet Clamp	66
Attaching the Clamp to a Vibrator	30	Model 196 J&M Sheet Clamp	68
Hooking up a Vibro to the Power Unit ..	31	Model 80 Caisson Clamp.....	70
Bleeding and Hooking Up Vibro Lines ..	32	Model 100 Caisson Clamp.....	72
Changing Clamp Jaws and Pile Guides..	33	Model 200 Caisson Clamp.....	74
Clamping Force Calculations	36	Model 20 Wood Clamp	76
Greasing the Clamp.....	37	Model 25 Wood Clamp	78
Clamp Thermal Relief	37	Model 32 Wood Clamp	80
Check Valve Test.....	37	Hybrid 20 Clamp	82
Worn Jaw Check	38	C102 Clamp.....	84
Fluid Cleanliness.....	39	Caisson Beam Adaptor	86
Storage	39	Seal Kits.....	88
Maintenance/Troubleshooting	40	Bolt Kits	89
Daily Checklist.....	40	References/Notes	90
Long Term Maintenance.....	41	Torque and Tension Requirements	90
Problem Identification	42	Understanding ISO Codes.....	91
Hydraulic Schematics	44	Target ISO Cleanliness Codes.....	92
		Revision Information.....	93
		User Notes	94

SPECIFICATIONS

Clamp and Vibro Compatibility

Vibro Type	Compatible Clamps		
50	<ul style="list-style-type: none"> • 50 Sheet Clamp • 150 Sheet Clamp • 200 Sheet Clamp • 126B Sheet Clamp 	<ul style="list-style-type: none"> • 196 Sheet Clamp • 100 Caisson Clamp • 200 Caisson Clamp • All Single Beams 	<ul style="list-style-type: none"> • C102 Wood Clamp • Hybrid Wood Clamp • 20 Wood Clamp • 25 Wood Clamp
100	<ul style="list-style-type: none"> • 50 Sheet Clamp • 150 Sheet Clamp • 200 Sheet Clamp • 126B Sheet Clamp 	<ul style="list-style-type: none"> • 196 Sheet Clamp • 100 Caisson Clamp • 200 Caisson Clamp • All Single Beams 	<ul style="list-style-type: none"> • C102 Wood Clamp • Hybrid Wood Clamp • 20 Wood Clamp • 25 Wood Clamp
150 / 150T	<ul style="list-style-type: none"> • 50 Sheet Clamp • 150 Sheet Clamp • 200 Sheet Clamp • 126B Sheet Clamp 	<ul style="list-style-type: none"> • 196 Sheet Clamp • 100 Caisson Clamp • 200 Caisson Clamp • All Single Beams 	<ul style="list-style-type: none"> • C102 Wood Clamp • Hybrid Wood Clamp • 20 Wood Clamp • 25 Wood Clamp
200 / 200T	<ul style="list-style-type: none"> • 150 Sheet Clamp • 200 Sheet Clamp • 126B Sheet Clamp • 196 Sheet Clamp 	<ul style="list-style-type: none"> • 100 Caisson Clamp • 200 Caisson Clamp • All Single Beams • C102 Wood Clamp 	<ul style="list-style-type: none"> • Hybrid Wood Clamp • 20 Wood Clamp • 25 Wood Clamp • 32 Wood Clamp
200-6	<ul style="list-style-type: none"> • 196 Sheet Clamp <i>Recommended</i> • 200 Sheet Clamp <i>Usable</i> 	<ul style="list-style-type: none"> • 200 Caisson Clamp • All Single Beams • 10' Quad beams 	<ul style="list-style-type: none"> • 20 Wood Clamp* • 25 Wood Clamp* • 32 Wood Clamp*
300	<ul style="list-style-type: none"> • 196 Sheet Clamp <i>Recommended</i> • 200 Sheet Clamp <i>Usable</i> 	<ul style="list-style-type: none"> • 200 Caisson Clamp • All Single Beams • 10' Quad Beam 	<ul style="list-style-type: none"> • 20 Wood Clamp* • 25 Wood Clamp* • 32 Wood Clamp*
300-6	<ul style="list-style-type: none"> • 196 Sheet Clamp <i>Recommended</i> • 200 Sheet Clamp <i>Usable</i> 	<ul style="list-style-type: none"> • 200 Caisson Clamp • 10' Quad Beam • All Single Beams 	<ul style="list-style-type: none"> • 20 Wood Clamp* • 25 Wood Clamp* • 32 Wood Clamp*
400	<ul style="list-style-type: none"> • 400 Sheet Clamp <i>Recommended</i> 	<ul style="list-style-type: none"> • 200 Caisson Clamp • All Single Beams • All Quad Beams 	<ul style="list-style-type: none"> • 196 Sheet Clamp <i>Usable</i>
600	<ul style="list-style-type: none"> • 400 Sheet Clamp <i>Recommended</i> 	<ul style="list-style-type: none"> • 200 Caisson Clamp • All Single Beams 	<ul style="list-style-type: none"> • All Quad beams

*Wood clamps need beam, caisson beam adaptor, and APE approval.

APE Sheet Clamps

Model	Weight			Piston Diameter				Piston Stroke				Cylinder Force			
20	750 lbs 340 kg			5 in 127 mm				2.25 in 57mm				44 short tons 391 kN			
50	1350 lbs 612 kg			8 in 203 mm				2.25 in 57mm				113 short tons 1005 kN			
150	1550 lbs 703 kg			8 in 203 mm				2.25 in 57mm				113 short tons 1005 kN			
200	2200 lbs 1000 kg			8 in 203 mm				2.25 in 57 mm				113 short tons 1005 kN			
400	7200 lbs 3265 kg			15 in 380 mm				2.85 in 72 mm				396 short tons 3519 kN			
/	A	B	C	D	E	F	G	H	J	K	L	M	N	P	R
20	33.25 in 845 mm	28.5 in 724 mm	10 in 254 mm	10 in 254 mm	21.63 in 549 mm	11.5 in 292 mm	2.22 in 56 mm	10.06 in 256 mm	8.13 in 207 mm	4.5 in 114 mm	4.88 in 124 mm	2.75 in 70 mm	8.25 in 210 mm	4 in 102 mm	12.32 in 313 mm
50	44 in 1118 mm	35 in 889 mm	12 in 305 mm	14 in 356 mm	23 in 584 mm	18.3 in 465 mm	1.44 in 37 mm	13.88 in 353 mm	5.77 in 147 mm	7 in 178 mm	5 in 127 mm	11 in 279 mm	8.25 in 210 mm	4 in 102 mm	16.32 in 414 mm
150	44 in 1118 mm	35 in 889 mm	12 in 305 mm	16 in 406 mm	29 in 737 mm	18.3 in 465 mm	1.44 in 37 mm	10.25 in 260 mm	5.88 in 149 mm	7 in 178 mm	5 in 127 mm	11 in 279 mm	8.25 in 210 mm	4 in 102 mm	16.32 in 414 mm
200	50 in 1270 mm	41 in 1041 mm	12 in 305 mm	15 in 381 mm	30.89 in 785 mm	18.2 in 462 mm	1.59 in 40 mm	10.31 in 262 mm	8.13 in 207 mm	7 in 178 mm	5.75 in 146 mm	8.25 in 210 mm	/	4 in 102 mm	22.19 in 564 mm
400	72.31 in 1837 mm	60 in 1524 mm	15.75 in 400 mm	22.12 in 562 mm	46 in 1168 mm	30.78 in 782 mm	2.86 in 73 mm	15.75 in 400 mm	10.94 in 278 mm	11.06 in 281 mm	6 in 152 mm	6.5 in 165 mm	8.25 in 210 mm	4 in 102 mm	25.06 in 637 mm
												/	S	T	U
												400	6 in 152 mm	2.75 in 70 mm	3.31 in 84 mm



**Model 400 with
two pile guides**

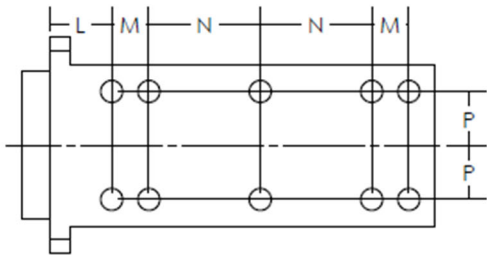

20 Bolt Pattern

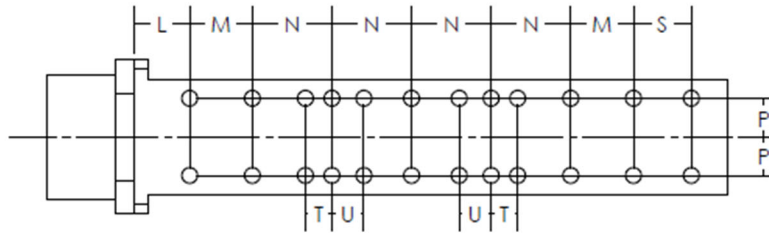

400 Bolt Pattern

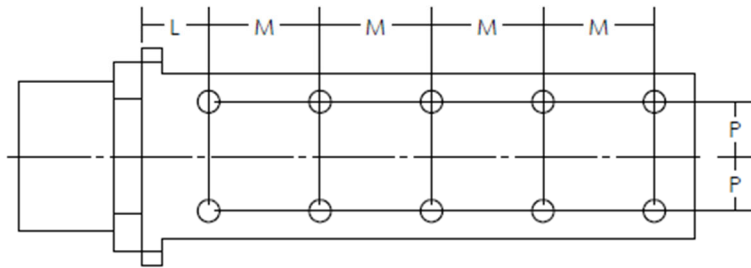

200 Bolt Pattern

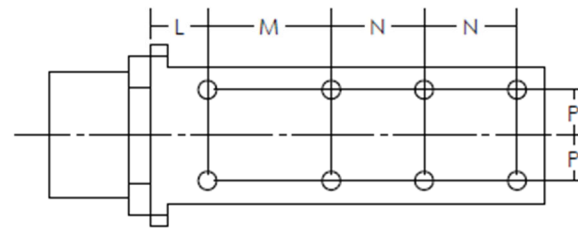

50/150 Bolt Pattern

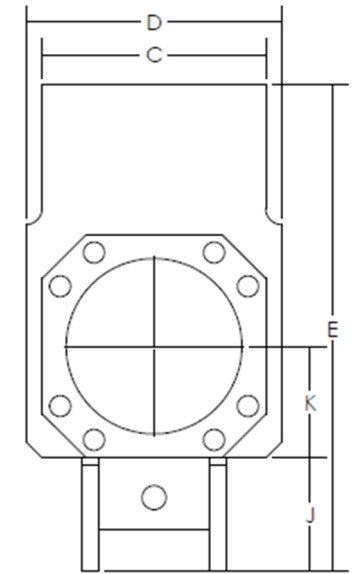

General Sheet Clamp Dimensions



Model 50

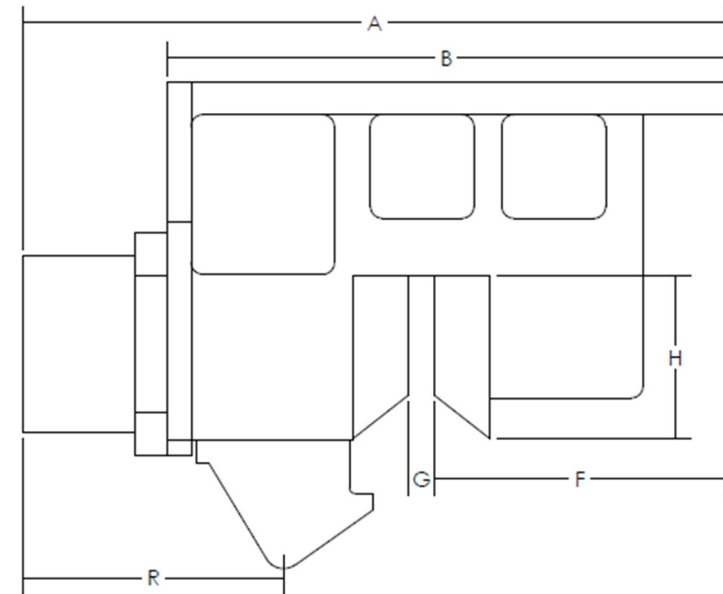

Special Sheet Clamps

Model	Weight			Piston Diameter				Piston Stroke				Cylinder Force				
50 Dunce	1350 lbs 612 kg			8 in 203 mm				2.25 in 57 mm				113 short tons 1005 kN				
150 Dunce	1550 lbs 705 kg			8 in 203 mm				2.25 in 57 mm				113 short tons 1005 kN				
126 J&M	2200 lbs 1000 kg			8 in 203 mm				1.86 in 47 mm				126 short tons 1120 kN				
196 J&M	2850 lbs 1295 kg			10 in 254 mm				3 in 76 mm				196 short tons 1744 kN				
300 APE	2850 lbs 1295 kg			10 in 254 mm				3 in 76 mm				196 short tons 1744 kN				
/	A	B	C	D	E	F	G	H	J	K	L	M	N	P	R	S
50 Dunce	44 in 112 cm	35 in 889 mm	12 in 305 mm	14 in 356 mm	25.88 in 657 mm	16.67 in 423 mm	1.71 in 43 mm	19.75 in 502 mm	11.18 in 284 mm	7 in 178 mm	8.7 in 221 mm	5 in 127 mm	11 in 279 mm	8.25 in 210 mm	4 in 102 mm	16.32 in 415 mm
150 Dunce	44 in 112 cm	35 in 889 mm	12 in 305 mm	16 in 406 mm	30.76 in 781 mm	16.67 in 423 mm	1.71 in 43 mm	18.69 in 475 mm	11.18 in 284 mm	7 in 178 mm	7.64 in 194 mm	5 in 127 mm	11 in 279 mm	8.25 in 210 mm	4 in 102 mm	16.32 in 415 mm
126 J&M	45.5 in 116 cm	37 in 940 mm	12 in 305 mm	12 in 305 mm	33 in 838 mm	18.61 in 473 mm	1.5 in 38 mm	10.88 in 276 mm	8.38 in 213 mm	8.31 in 211 mm	7 in 178 mm	8.25 in 210 mm	11 in 279 mm	4 in 102 mm	18.88 in 480 mm	/
196 J&M	57 in 145 cm	45.25 in 120 cm	12 in 305 mm	15 in 381 mm	35.25 in 819 mm	22.63 in 575 mm	2.5 in 64 mm	10.88 in 276 mm	9 in 229 mm	7.38 in 187 mm	5.88 in 149 mm	8.25 in 210 mm	4.28 in 109 mm	4 in 102 mm	24.13 in 613 mm	/
300 APE	57 in 145 cm	45.25 in 120 cm	12 in 305 mm	15 in 381 mm	34.75 in 883 mm	22.63 in 575 mm	2.84 in 72 mm	10.63 in 270 mm	9.56 in 243 mm	7.38 in 187 mm	5.88 in 149 mm	8.25 in 210 mm	4.28 in 109 mm	4 in 102 mm	24.38 in 619 mm	/

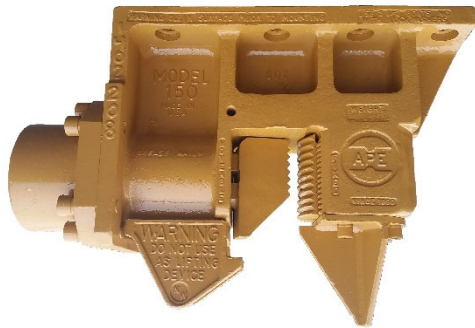

Dunce Clamp Dimensions

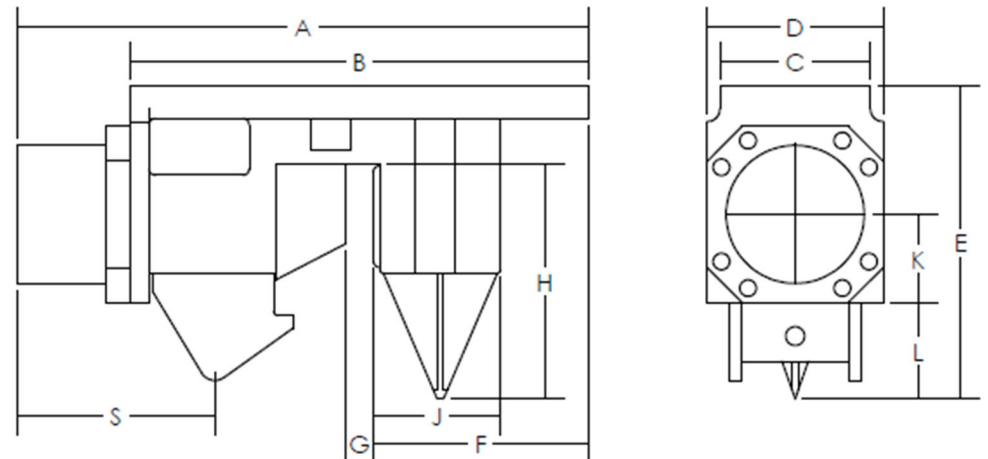

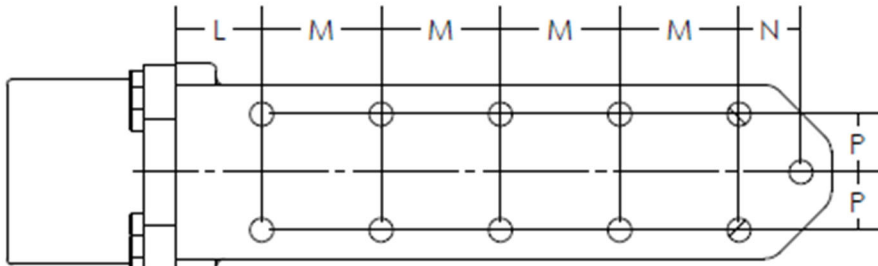

**J&M 196 / APE 300
Bolt Configuration**

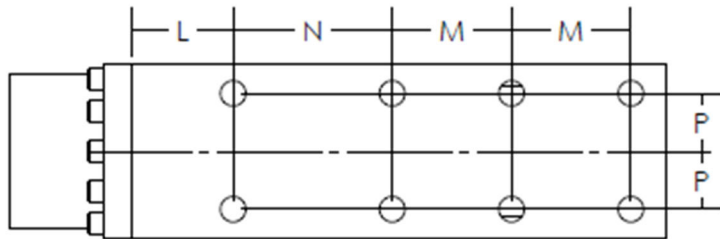

**J&M 126 Bolt
Configuration**

**J&M 196 / J&M 126 / APE 300
Dimensions**

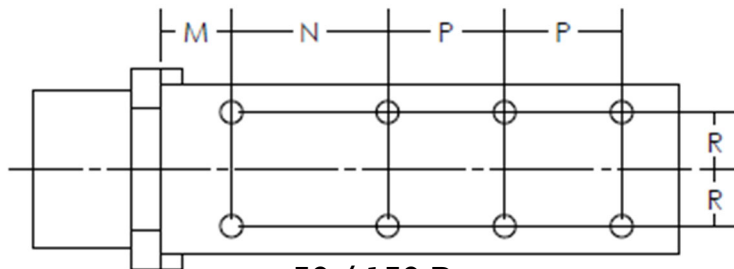

**50 / 150 Dunce
Bolt Configuration**

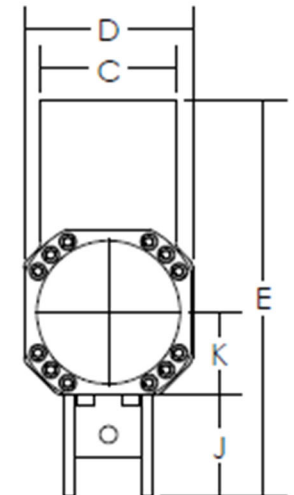
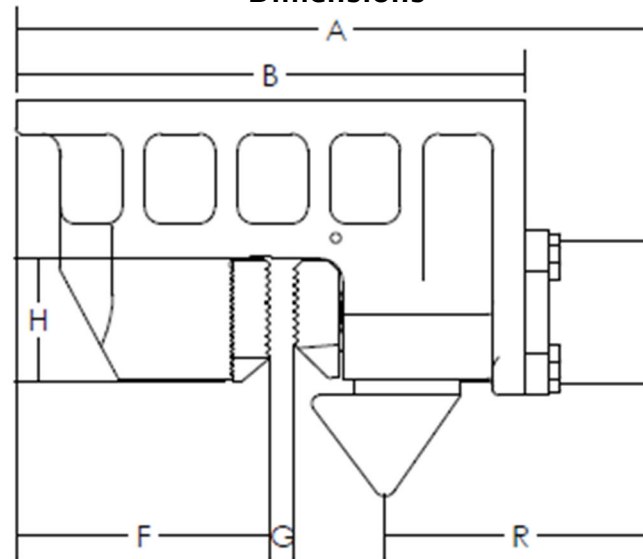

Wood / Concrete Clamps

Model	Weight				Piston Diameter				Cylinder Force					
20	5900 lbs 2675 kg				7 in 178 mm				67 short tons 600 kN					
25	6500 lbs 2950 kg				7 in 178 mm				67 short tons 600 kN					
32	9100 lbs 4130 kg				7 in 178 mm				67 short tons 600 kN					
/	A	B	C	D	E	F	G	H	J	K	L	M	N	P
20	44 in 1118 mm	42.75 in 1086 mm	44 in 1118 mm	20 in 508 mm	71.5 in 1816 mm	61.5 in 1562 mm	6.0 in 152 mm	32 in 813 mm	14 in 356 mm	26.75 in 679 mm	7 in 178 mm	8.25 in 210 mm	4 in 102 mm	/
25	56.75 in 1441 mm	47.84 in 1215 mm	52.25 in 1327 mm	25.5 in 648 mm	84.25 in 2140 mm	74 in 1880 mm	6.25 in 159 mm	35 in 889 mm	14 in 356 mm	30.75 in 781 mm	7.19 in 183 mm	8.25 in 210 mm	4 in 102 mm	/
32	62.75 in 1594 mm	53.55 in 1360 mm	54.75 in 1391 mm	32 in 813 mm	86.25 in 2191 mm	74 in 1880 mm	6.0 in 152 mm	43.33 in 1101 mm	14 in 356 mm	38.25 in 972 mm	4.35 in 111 mm	8.25 in 210 mm	4 in 102 mm	6.5 in 165 mm

**Model 20/25
Bolt Configuration**

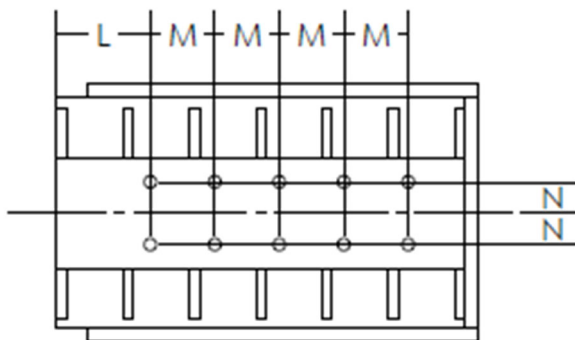

**Model 32
Bolt Configuration**

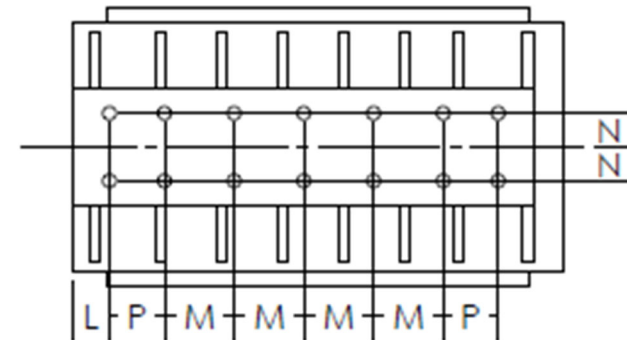

Common Appearance and Main Dimensions

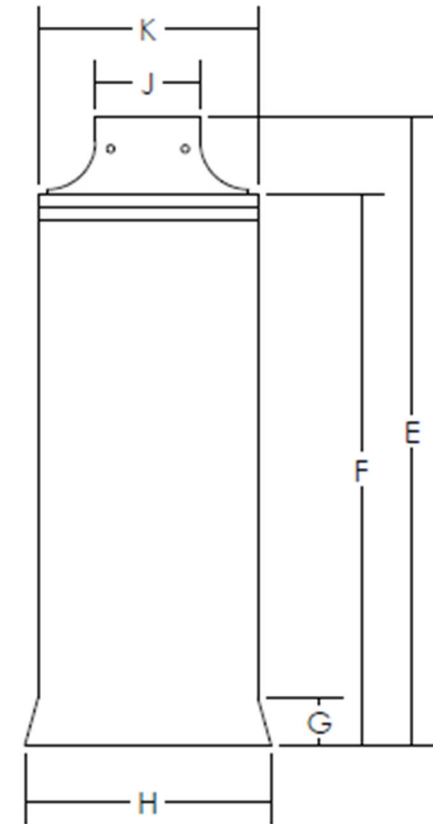
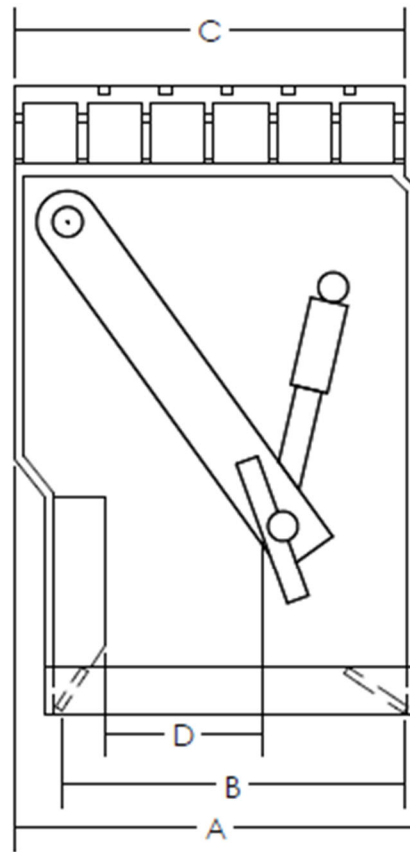

Wood / Concrete Clamps (Continued)

Model	Weight			Piston Diameter			Cylinder Force		
C102	3250 lbs 1475 kg			4 in 102 mm			30.5 short tons 271 kN		
20 Hyb.	3800 lbs 1725 kg			4 in 102 mm			30.5 short tons 271 kN		
/	A	B	C	D	E	F	G	H	J
C102	49.75 in 1264 mm	46.75 in 1188 mm	40.5 in 1042 mm	15.5 in 394 mm	33 in 838 mm	4 in 102 mm	1.88 in 48 mm	3.5 in 89 mm	5.5 in 140 mm
20 Hyb.	55.25 in 1403 mm	52.25 in 1327 mm	40.5 in 1042 mm	20 in 508 mm	38.5 in 978 mm	4 in 102 mm	1.88 in 48 mm	3.5 in 89 mm	5.38 in 137 mm
/	K	L	M	N	P	Q	R	S	T
C102	6.06 in 154 mm	4.94 in 125 mm	8.25 in 210 mm	5.75 in 146 mm	4.31 in 110 mm	3.69 in 94 mm	1.81 in 46 mm	10.94 in 278 mm	6 in 152 mm
20 Hyb.	8.25 in 210 mm	7.13 in 181 mm	8 in 203 mm	12.75 in 324 mm	6 in 152 mm	/	/	/	/

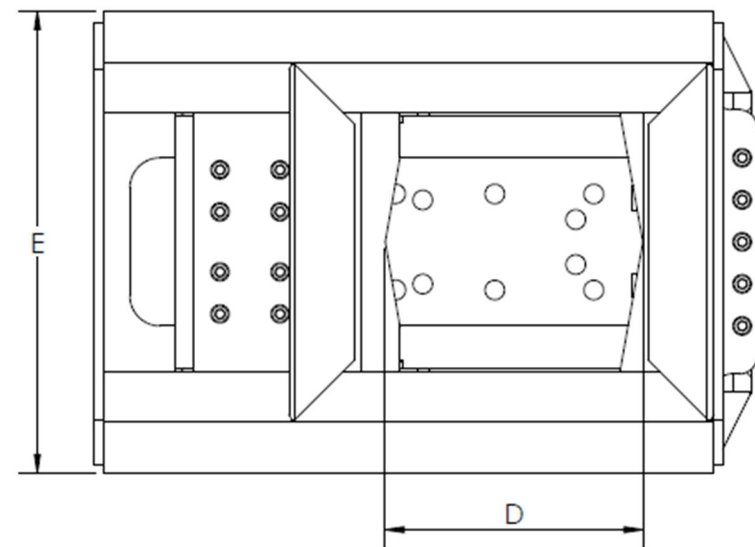
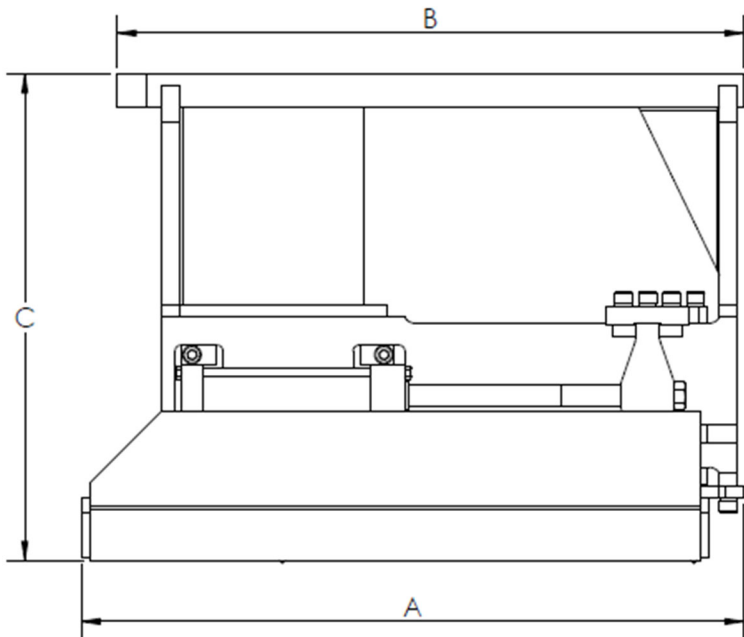



**C102 Mounted on
Model 50 Vibro**

C102 Bolt Pattern

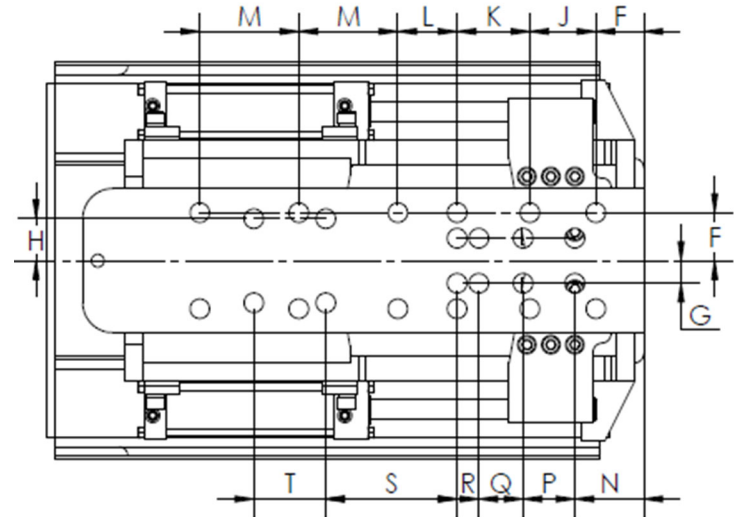

**Model 20 Hybrid
Bolt Pattern**

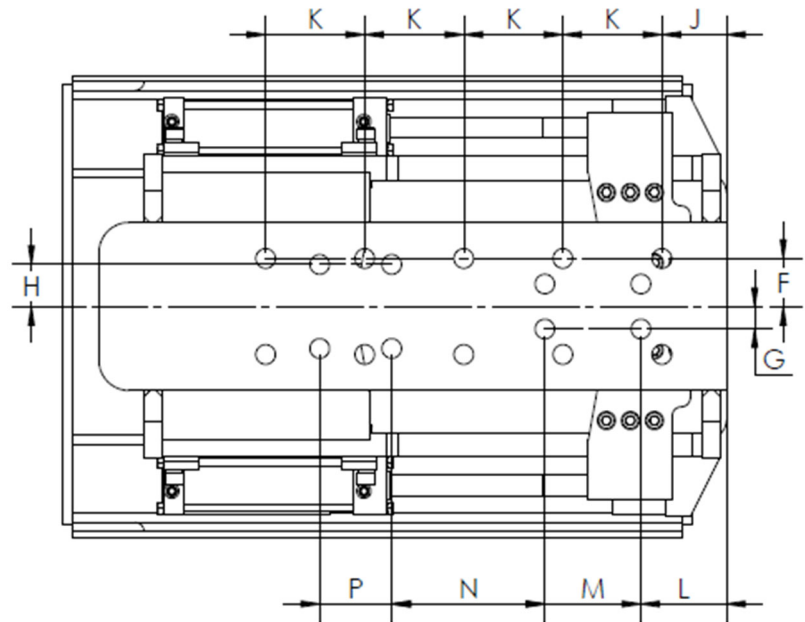

Standard Caisson Beams

Model	Weight	A	B	C	D	E	F	G	H
5 ft	1100 lbs 500 kg	60 in 1524 mm	/	13.41 in 341 mm	4 in 102 mm	13.38 in 340 mm	5.9 in 150 mm	2.91 in 74 mm	4.94 in 125 mm
8 ft	1500 lbs 680 kg	96 in 2438 mm	84 in 2134 mm	13.75 in 349 mm	4 in 102 mm	12 in 305 mm	5.9 in 150 mm	2.91 in 74 mm	4.94 in 125 mm
11 ft	3500 lbs 1590 kg	132.5 in 3366 mm	120 in 3048 mm	13.41 in 341 mm	4 in 102 mm	12 in 305 mm	5.9 in 150 mm	3 in 76 mm	4.94 in 125 mm
13 ft	3600 lbs 1635 kg	156 in 3962 mm	/	18 in 457 mm	4 in 102 mm	13.5 in 343 mm	5.9 in 150 mm	2.91 in 74 mm	4.94 in 127 mm
/	J	K	L	M	N	P	R	S	T
5 ft	3.31 in 84 mm	2.75 in 70 mm	5.5 in 140 mm	6.5 in 165 mm	/	/	/	/	/
8 ft	3.31 in 84 mm	2.75 in 70 mm	5.5 in 140 mm	6.5 in 165 mm	6 in 152 mm	8 in 203 mm	/	/	/
11 ft	3.31 in 84 mm	2.75 in 70 mm	5.5 in 140 mm	6.5 in 165 mm	6 in 152 mm	8 in 203 mm	9 in 229 mm	/	/
13 ft	3.31 in 84 mm	2.75 in 70 mm	5.5 in 140 mm	6.5 in 165 mm	6 in 152 mm	8 in 203 mm	9 in 229 mm	3 in 76 mm	12 in 305 mm

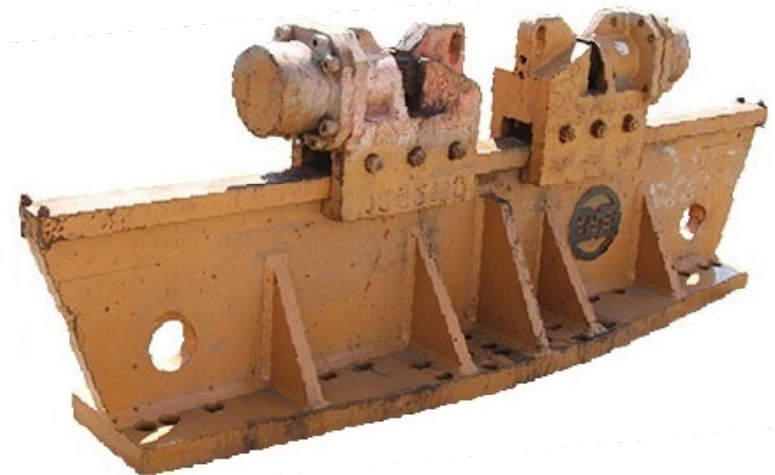

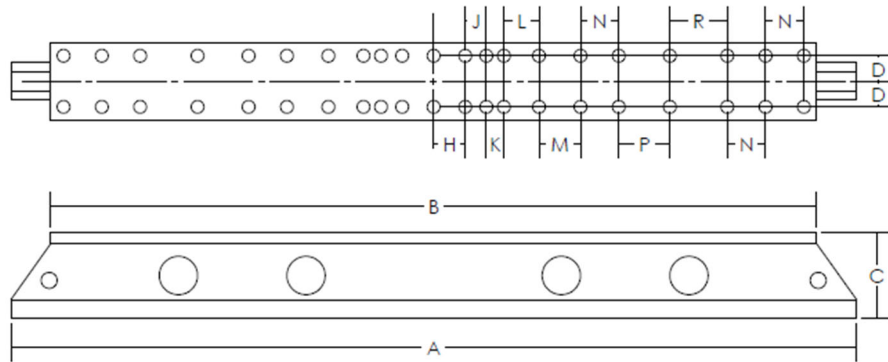

11 ft and 8 ft Beam

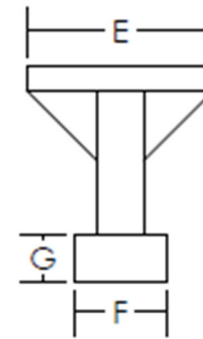

Common Profile

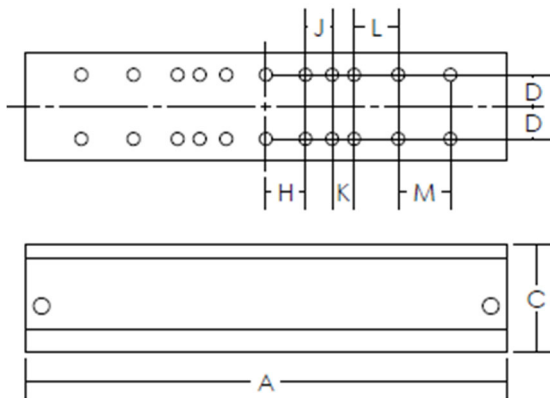

5 ft Beam

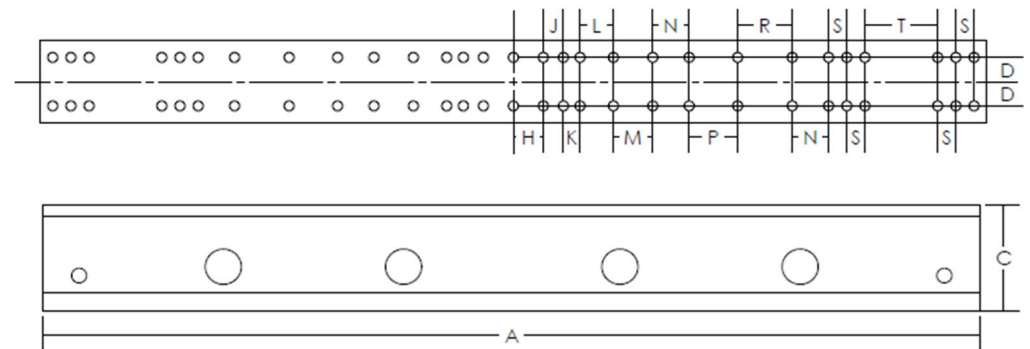

13 ft Beam

Caisson Quad Beams

Model	Weight	A	B	C	D	E	F	G	H	J	K	L
10 ft	7000 lbs 3175 kg	120 in 3048 mm	118 in 2997 mm	22 in 559 mm	12 in 305 mm	24 in 610 mm	5.9 in 150 mm	4 in 102 mm	4.25 in 108 mm	4 in 102 mm	4.25 in 108 mm	2.75 in 70 mm
11 ft	7700 lbs 3500 kg	132 in 3353 mm	141.5 in 3594 mm	31 in 787 mm	12 in 305 mm	30 in 762 mm	5.9 in 150 mm	4 in 102 mm	4.25 in 108 mm	4 in 102 mm	5 in 127 mm	7.5 in 191 mm
12 ft	8650 lbs 3920 kg	144 in 3658 mm	144 in 3658 mm	28.38 in 721 mm	12 in 305 mm	24 in 610 mm	5.9 in 150 mm	4 in 102 mm	4.25 in 108 mm	4 in 102 mm	4.25 in 108 mm	2.75 in 70 mm
15 ft	15300 lbs 6940 kg	180 in 4572 mm	173 in 4394 mm	31 in 787 mm	31 in 787 mm	30 in 762 mm	5.9 in 150 mm	4 in 102 mm	4.25 in 108 mm	4 in 102 mm	5 in 127 mm	7.5 in 191 mm
17 ft	21800 lbs 9900 kg	204 in 5182 mm	197 in 5004 mm	31 in 787 mm	22 in 559 mm	40 in 1016 mm	5.9 in 150 mm	4 in 102 mm	4.25 in 108 mm	4 in 102 mm	5 in 127 mm	7.5 in 191 mm
/	M	N	P	R	S	T	U	V	W	X	Y	
10 ft	5.5 in 140 mm	6.5 in 165 mm	6 in 152 mm	8 in 203 mm	9 in 229 mm	4.5 in 114 mm	6.5 in 165 mm	6 in 152 mm	8 in 203 mm	9 in 229 mm	/	
11 ft	6.5 in 165 mm	6 in 152 mm	17 in 432 mm	6 in 152 mm	3 in 76 mm	5.5 in 140 mm	6.5 in 165 mm	6 in 152 mm	8 in 203 mm	9 in 229 mm	3 in 76 mm	
12 ft	5.5 in 140 mm	6.5 in 165 mm	6 in 152 mm	8 in 203 mm	9 in 229 mm	2.25 in 57 mm	6.5 in 165 mm	6 in 152 mm	8 in 203 mm	9 in 229 mm	/	
15 ft	6.5 in 165 mm	6 in 152 mm	17 in 432 mm	6 in 152 mm	3 in 76 mm	4 in 102 mm	6 in 152 mm	17 in 432 mm	6 in 152 mm	3 in 76 mm	/	
17 ft	6.5 in 165 mm	6 in 152 mm	17 in 432 mm	6 in 152 mm	3 in 76 mm	4 in 102 mm	6 in 152 mm	17 in 432 mm	6 in 152 mm	3 in 76 mm	12 in 305 mm	

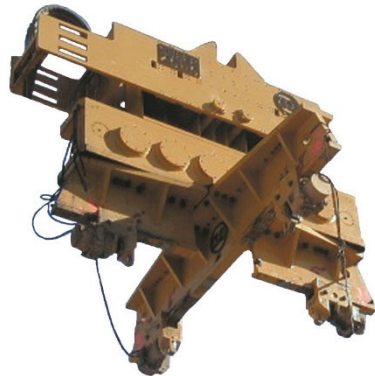

Common Profile

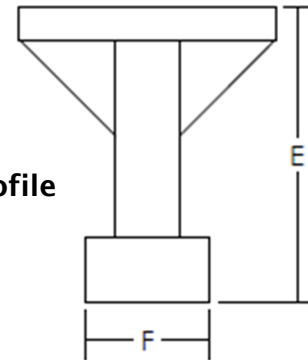

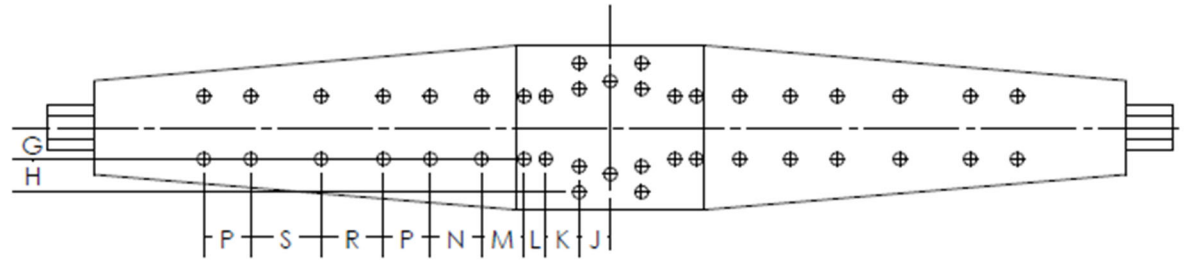
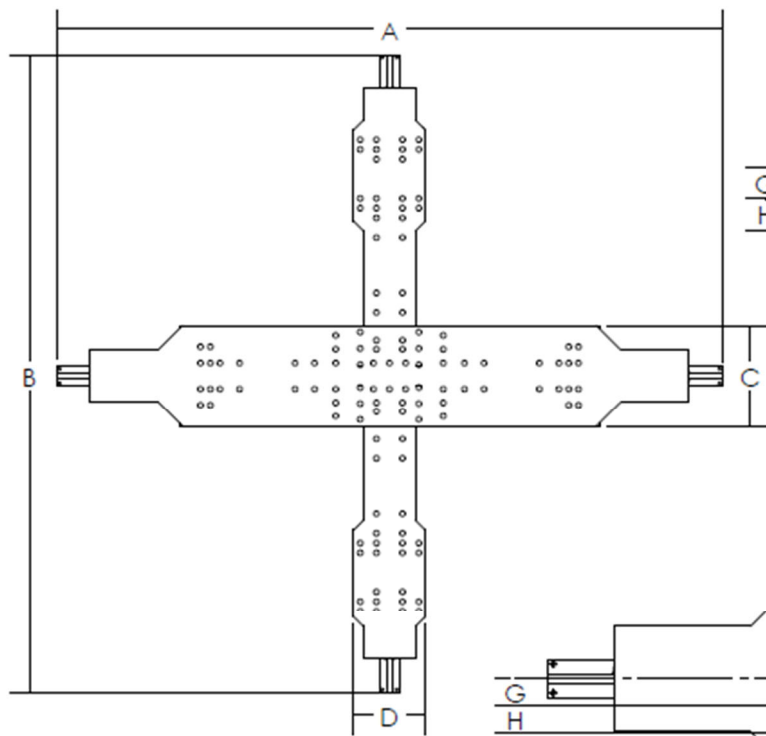

**12 ft, 10 ft
Main Beam Bolt Configuration**

**17 ft, 15 ft, 11 ft
Main Beam Bolt Configuration**

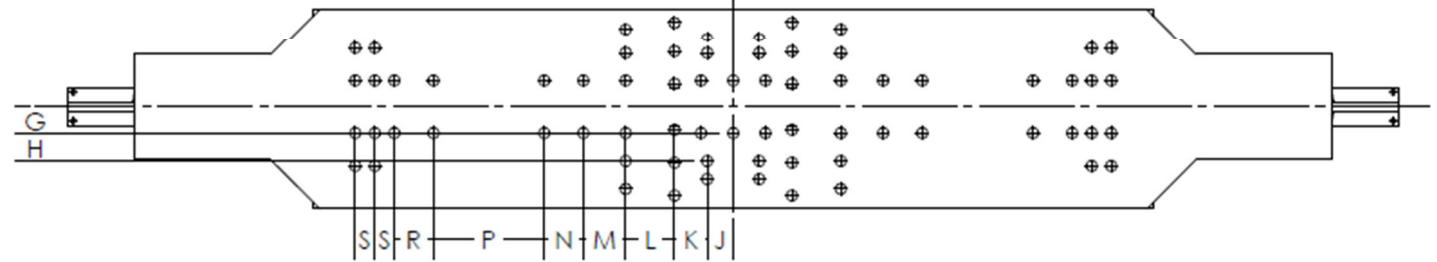

**10 ft, 11 ft, 12 ft
Side Beam Bolt Configuration**

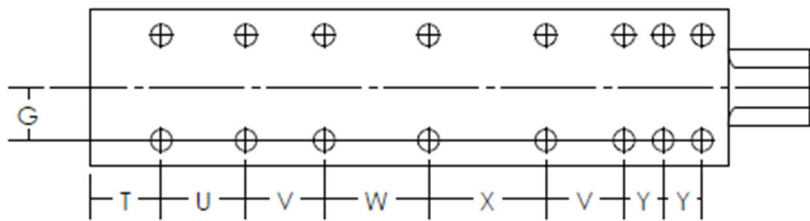

**17 ft, 15 ft
Side Beam Bolt Configuration**

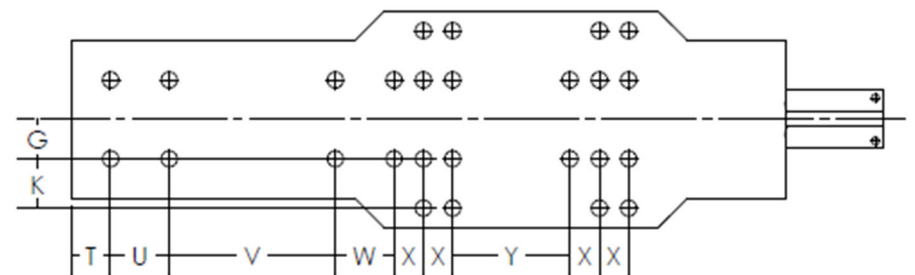

Caisson Clamps

Model	Weight		Piston Diameter			Piston Stroke		Cylinder Force		
80	1050 lbs 475 kg		7 in 178 mm			2 in 51 mm		86.5 short tons 770 kN		
100	1,150 lbs 520 kg		8 in 203 mm			2.25 in 57 mm		113 short tons 1,005 kN		
200	1,350 lbs 610 kg		8 in 203 mm			2.25 in 57 mm		113 short tons 1,005 kN		
/	A	B	C	D	E	F	G	H	J	K
80	27.88 in 708 mm	19 in 483 mm	11 in 279 mm	11 in 279 mm	22 in 559 mm	7 in 178 mm	1.5 in 38 mm	11.13 in 283 mm	7.25 in 184 mm	5.75 in 146 mm
100	27.63 in 702 mm	18.63 in 473 mm	11 in 279 mm	14 in 356 mm	23.38 in 594 mm	6.7 in 170 mm	1.5 in 38 mm	10.88 in 276 mm	6.87 in 175 mm	7.25 in 184 mm
200	34 in 864 mm	25 in 635 mm	11 in 279 mm	14 in 356 mm	23.38 in 594 mm	10.8 in 274 mm	1.5 in 38 mm	10.88 in 276 mm	7 in 178 mm	7.25 in 184 mm

200 Caisson

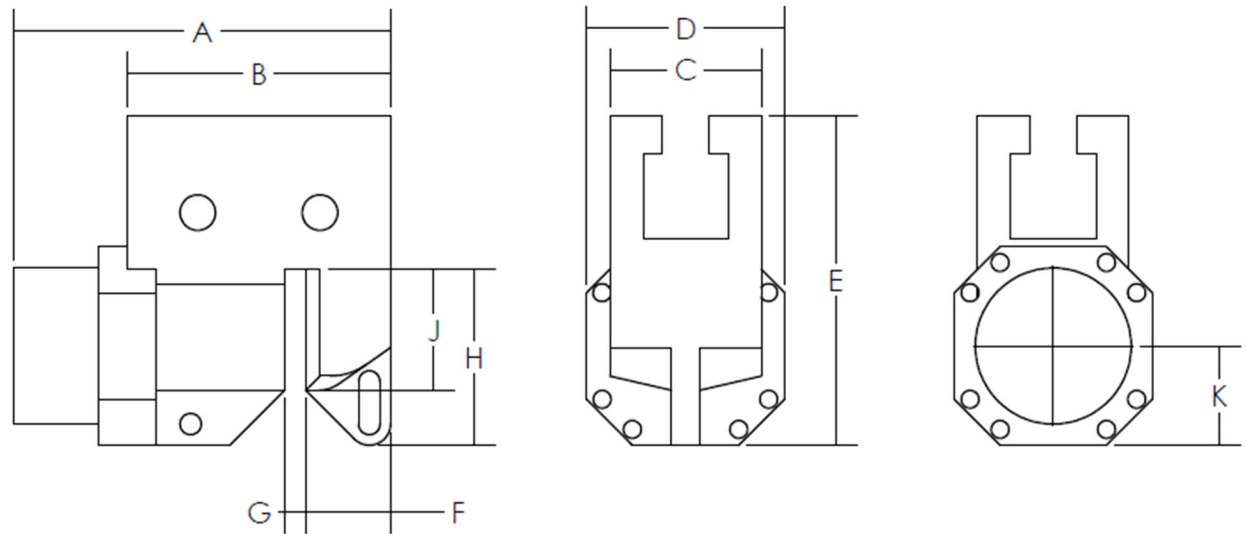

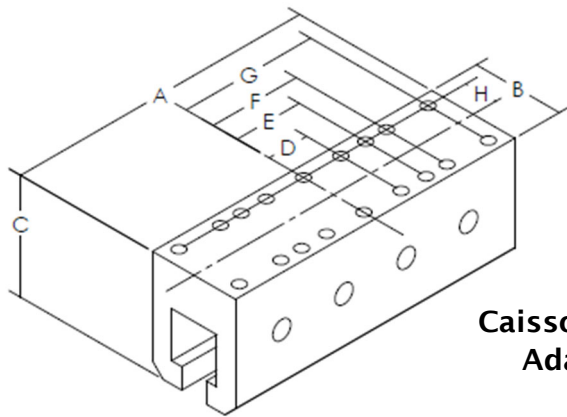

Caisson Beam Adaptor



Extension

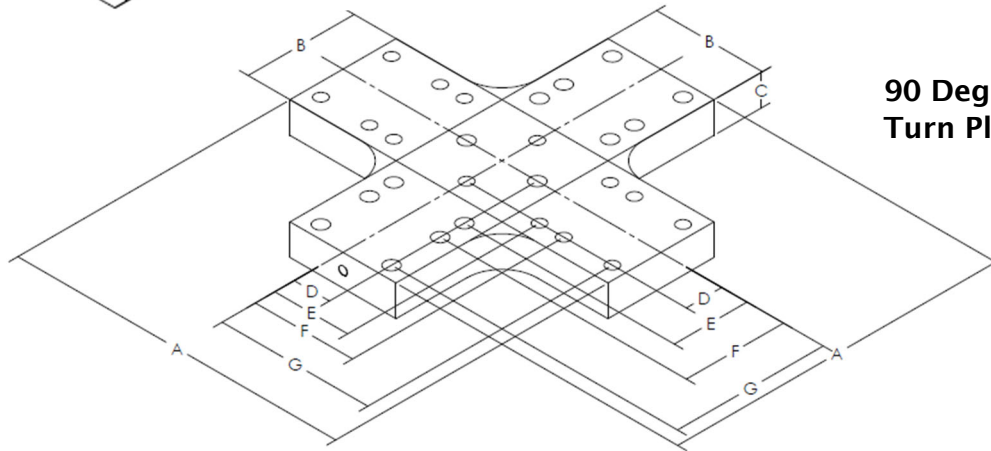
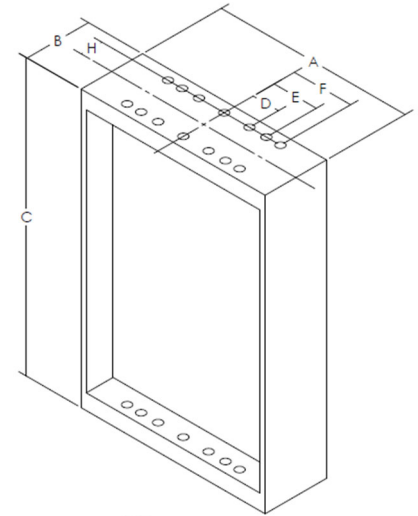

90 Degree Turn Plate



Item	Weight	A	B	C	D	E	F	G	H
Caisson Beam Adaptor	1170 lbs 530 kg	37 in 940 mm	11 in 279 mm	14 in 357 mm	4.94 in 125 mm	8.25 in 210 mm	11 in 279 mm	16.5 in 419 mm	4 in 102 mm
4' Extension	2500 lbs 1135 kg	36 in 914 mm	12 in 305 mm	54 in 1372 mm	4.94 in 125 mm	8.25 in 210 mm	11 in 279 mm	/	4 in 102 mm
8' Extension	4000 lbs 1815 kg	36 in 914 mm	12 in 305 mm	102 in 2591 mm	4.94 in 125 mm	8.25 in 210 mm	11 in 279 mm	/	4 in 102 mm
90 Degree Turn Plate	800 lbs 365 kg	36 in 914 mm	12 in 305 mm	3.5 in 89 mm	4 in 102 mm	8.25 in 210 mm	11 in 279 mm	16.5 in 419 mm	4 in 102 mm

Other Clamp Accessories

Small and Gearbox Incorporated Universal Clamps

Item	Weight		Piston Diameter				Piston Stroke			Cylinder Force**		A	B
Special Model 6	70 lbs 31.75 kg		3.35 in 85.1 mm				1.68 in 42.7 mm			13 short tons 117 kN		5.0 in 127 mm	1.06 in 27 mm
Standard Model 6	660 lbs* 300 kg*		3.49 in 88.6 mm				2 in 50.8 mm			14 short tons 127.7 kN		9.5 in 241.3 mm	1.25 in 31.75 mm
Model 9	900 lbs* 408 kg*		3.49 in 88.6 mm				2 in 50.8 mm			14 short tons 127.7 kN		9.5 in 241.3 mm	1.25 in 31.75 mm
/	C	D	E	F	G	H	J	K	L	M	N	P	Q
Special Model 6	9.5 in 241.3 mm	5.5 in 139.7 mm	6.38 in 161.9 mm	11 in 279.4 mm	15 in 381 mm	5.25 in 133.4 mm	4.13 in 104.8 mm	4.75 in 120.7 mm	1 in 25.4 mm	3.06 in 77.8 mm	2.25 in 57.2 mm	5.38 in 136.5 mm	8.38 in 212.7 mm
Standard Model 6	13.25 in 336.6 mm	14.81 in 376.2 mm	9.5 in 241.3 mm	4.63 in 117.5 mm	30.13 in 765.2 mm	5.79 in 147.1 mm	4.13 in 104.8 mm	4.38 in 111.1 mm	1 in 25.4 mm	5.46 in 138.7 mm	/	/	/
Model 9	13.25 in 336.6 mm	21.9 in 556.3 mm	9.5 in 241.3 mm	4.63 in 117.5 mm	44.38 in 112.7 cm	5.92 in 150.4 mm	4.25 in 108 mm	4.38 in 111.1 mm	1 in 25.4 mm	5.59 in 142 mm	/	/	/

*Clamp is component of vibratory hammer; this value represents the full weight of the unit.

**Cylinder and force from 300 psi pressure setting.

**Model 3 Vibro
with Special
Model 6 Clamp**



**Model 6 Vibro
with built in
Standard Model 6
Clamp**



Model 9 Vibro gearbox with built in clamp

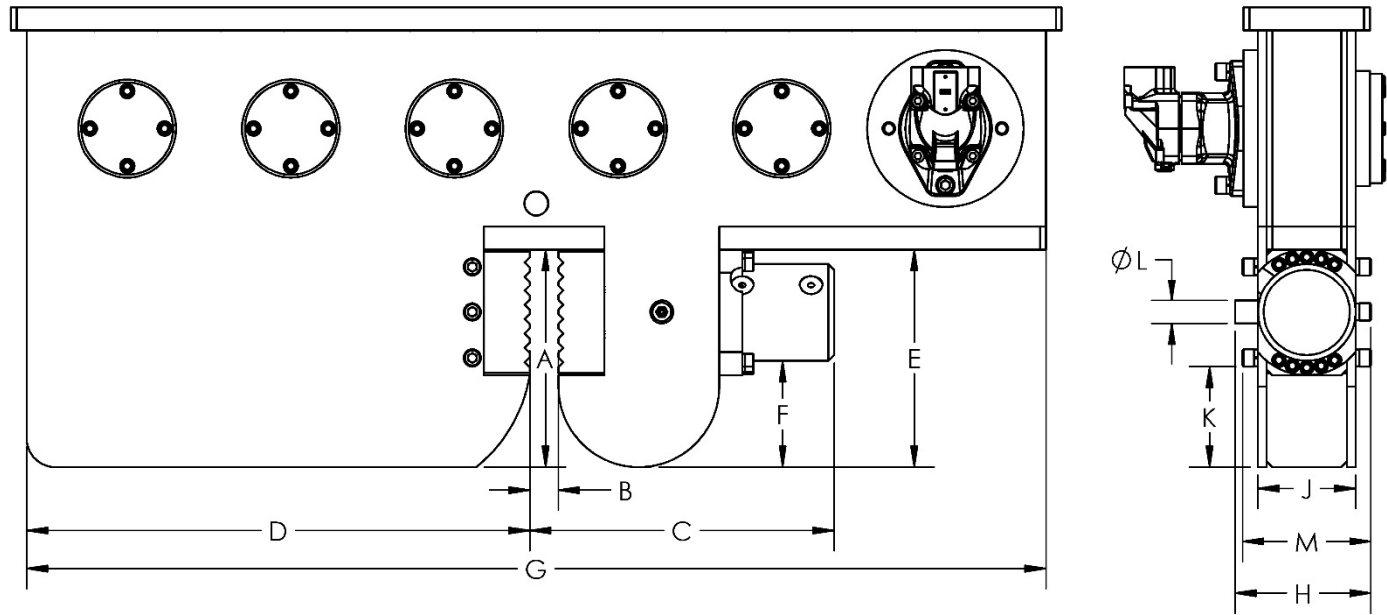

Model 6 Special Clamp

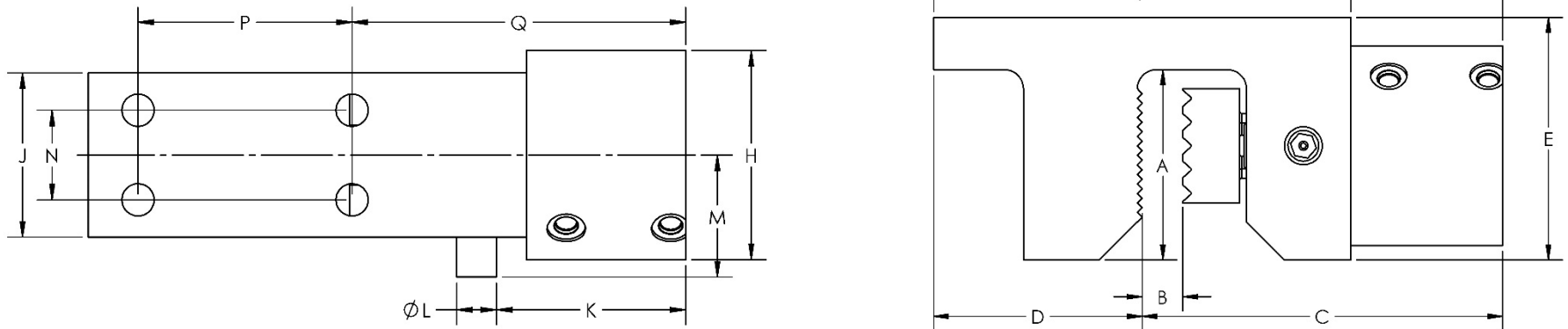

OPERATORS INFORMATION

Component Overview

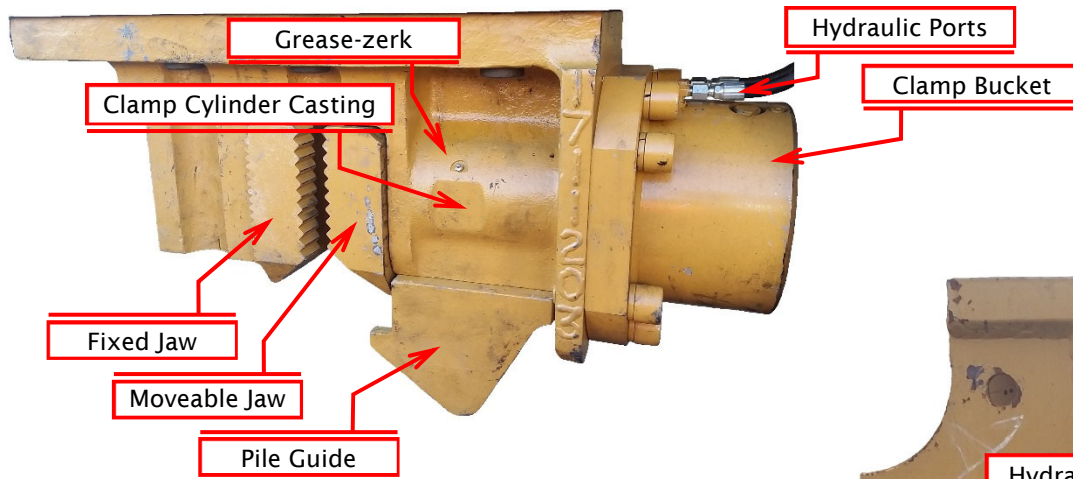

Common Sheet Clamp

Wood Clamp

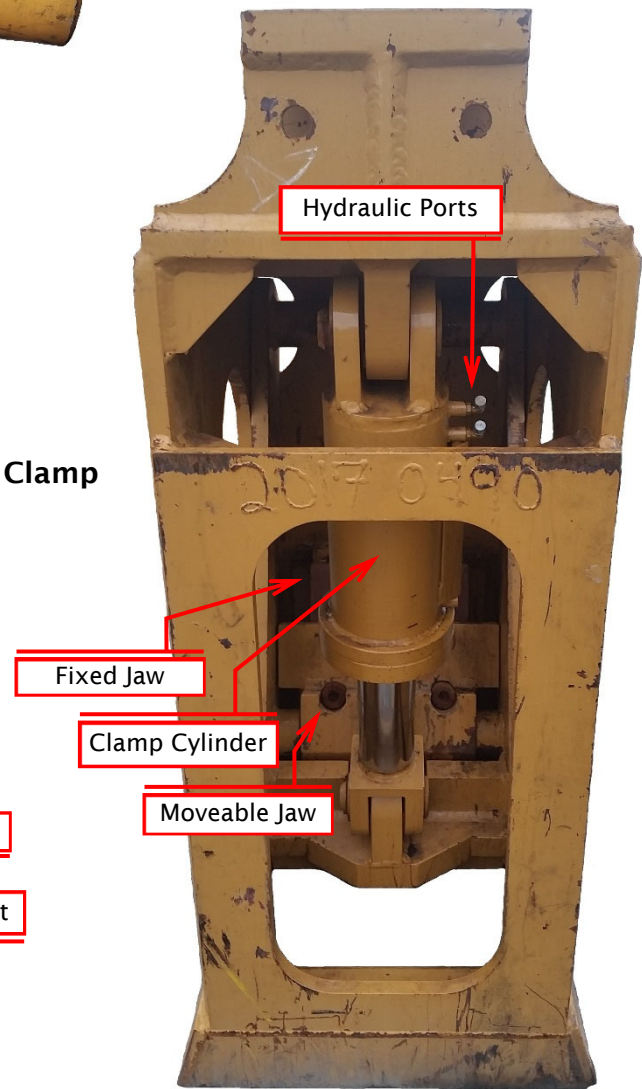

Caisson Clamp on Beam

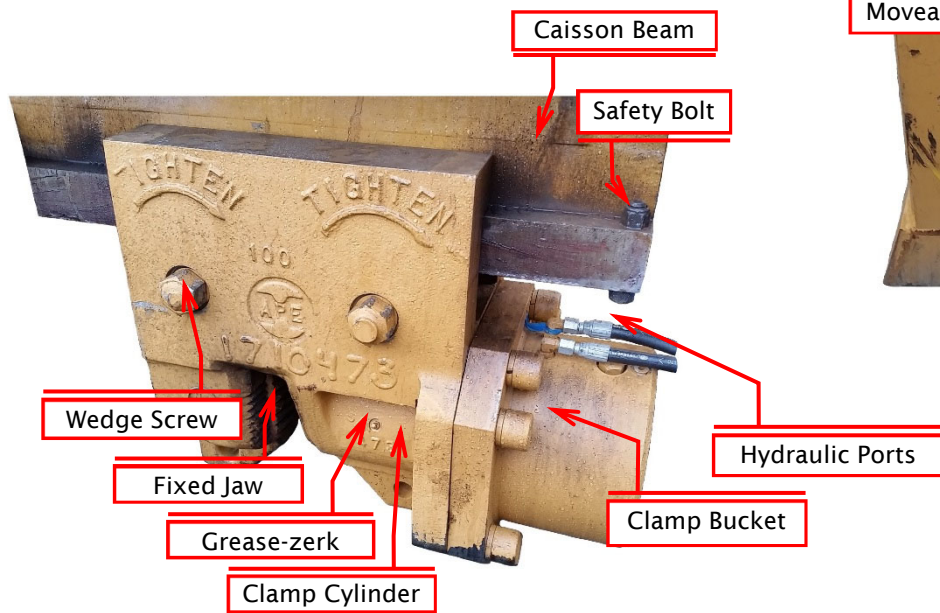



Emergency Stop

Engine Throttle

Wired Control Pendant

Clamp Switch

Drive Switch

Standard Power Unit Console

Engine Throttle

Clamp Switch

Drive Switch

Remote vs Local Toggle

Engine Start / Power On

Digital Power Unit Console

Emergency Stop

Clamp Switch

Power On

Engine Throttle

Drive Switch

Remote vs Local Toggle

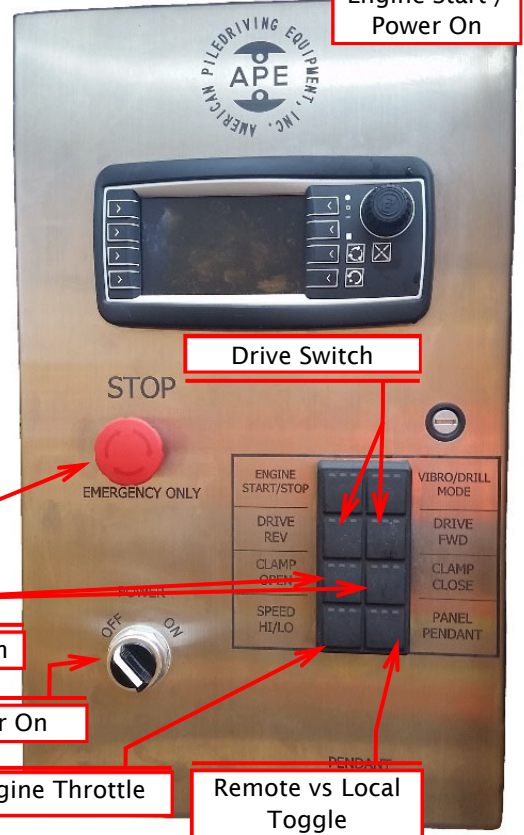

OPERATORS INFORMATION

Labels and Warnings

Model Number
Cast on the clamp body, usually near the cylinder, this number is essential when contacting APE for parts or service.

Warning clean surface prior to mounting.
Clean mating surfaces before attaching clamp to vibro. Dirt or debris may cause improper mating and broken bolts.

Use 3-1/2" bolts NC with lockwashers.
Specifies which bolts to use when attaching the clamp to a vibro.

Serial Number
Also found welded on the top lip, this number is essential when contacting APE for parts or service.

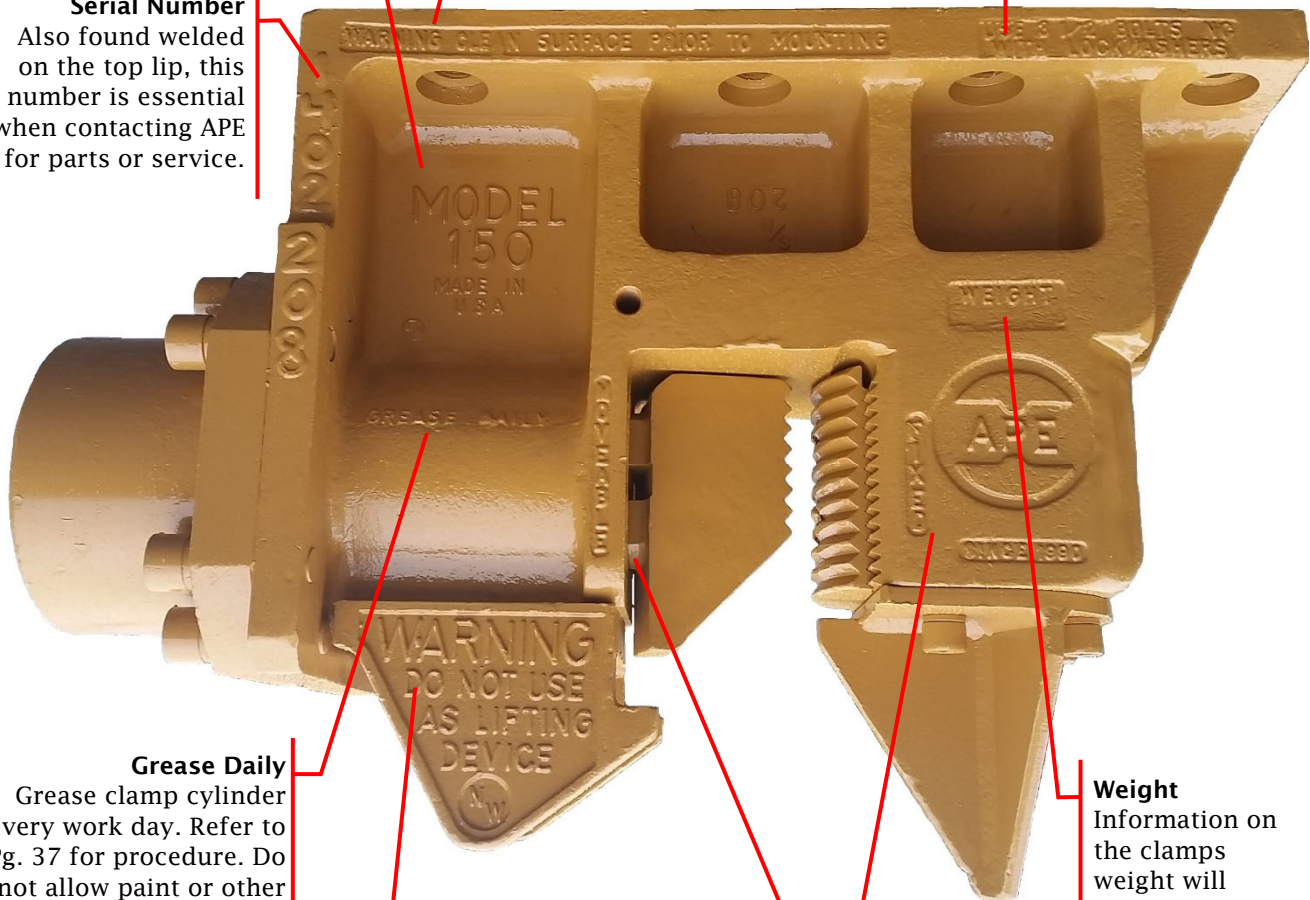

Grease Daily
Grease clamp cylinder every work day. Refer to Pg. 37 for procedure. Do not allow paint or other foreign material to block the grease fitting.

Warning Do not use as lifting device
Do not use clamp to lift piles. Clamp may lose pressure and drop load, causing property damage, serious injury, or death.

Weight
Information on the clamps weight will often be cast on the body.

Moveable / Fixed
Most clamp castings will indicate which side of the clamp jaws are moveable and fixed. The moveable jaw will always be on the same side of the clamp as the clamp bucket.

Clamp Bucket Face
Often contains information on cylinder diameter, stroke length, and clamp seals.

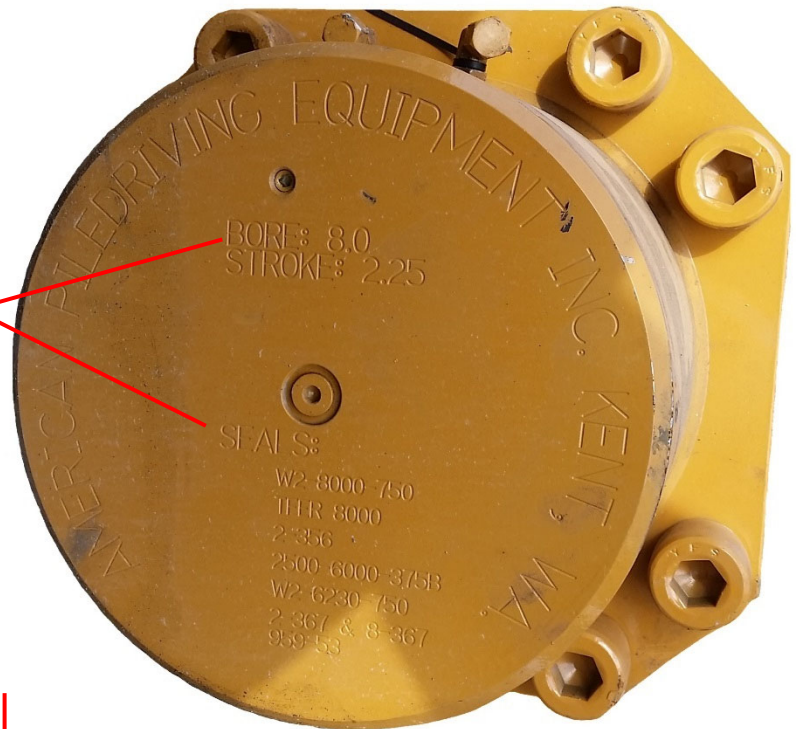

Tighten
Tighten or loosen caisson wedge bolts only from the side where the TIGHTEN label is displayed. Attempting to tighten from the incorrect side may damage the clamp.

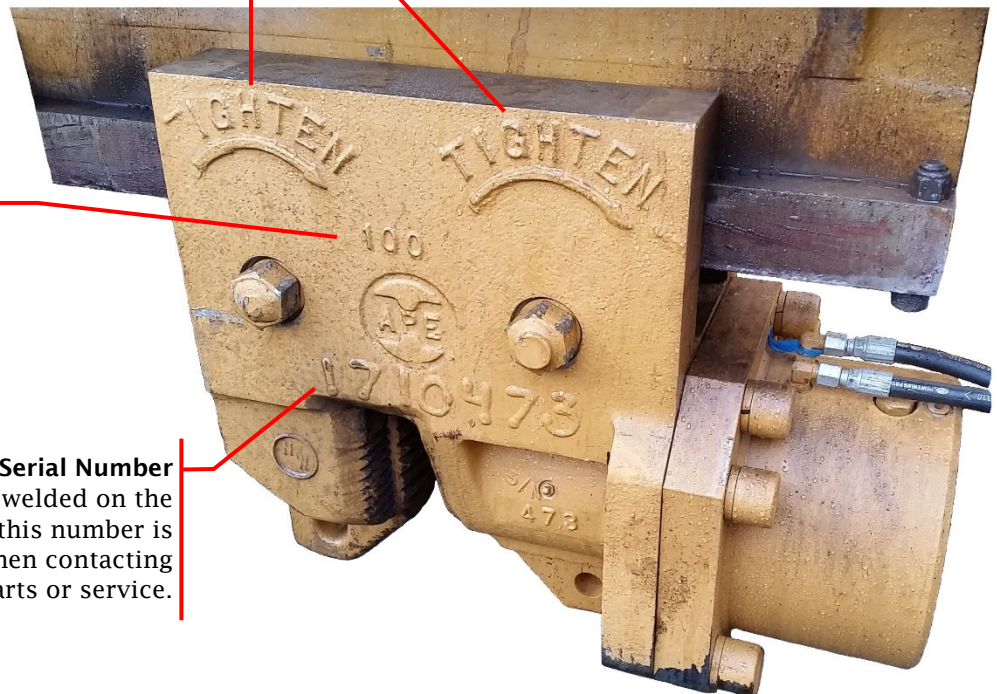

Model Number
Cast on the clamp body, usually near the cylinder, this number is essential when contacting APE for parts or service.

Serial Number
Also found welded on the top lip, this number is essential when contacting APE for parts or service.

OPERATORS INFORMATION

Attaching the Clamp to a Vibrator

The vibrator is usually shipped with the hydraulic clamp already attached and hooked up. If this is not so, or the job requires multiple clamps to be used on the same vibrator, a working knowledge of how to change the clamp is necessary. All bolts should be socket head cap screws. Do not use grade five bolts.

These instructions are written with sheet clamps in mind. They are also appropriate for attaching turn plates, extensions, caisson beams, and caisson adaptors.

1. Clean all drilled and tapped threads on the bottom surface of the gearbox. Use a 1½-6 UNC tap to clean rusted threads then blow out remaining fragments with compressed air. If there is a cutting torch on the jobsite then use the oxygen setting to blast the threads clean. Hold a rag over the tapped hole to prevent flying dirt from blasting into eyes.
2. Clean both the machined bottom surface of the gearbox and the surface of the clamp/attachment. Make sure the surfaces are flat and void of all dirt. Eyeball the surface for damage.
3. Orient the clamp/attachment holes with those of the vibrator. If attaching a sheet clamp, place the clamp bucket on the same side as the vibrator hoses when possible.
4. Insert the center bolt first and work outwards. Use anti-seize and note the K value.
5. Tighten bolts according to the torque specifications in the Reference section on Pg. 90. Go around all bolts at least three times making sure they are tight.
6. After vibrating the first pile check the bolts again.
7. If one bolt breaks replace them all since they may be weak or cracked.
8. Never operate the vibrator with missing clamp/attachment bolts.

Clamp and Beam Mounting Bolts		
Type	1.5 - 6x3.5"	1.5 - 6x5.0"
20 Sheet	10	-
50 Sheet	8	-
150 Sheet	8	-
200 Sheet	10	-
400 Sheet	24	-
126 Sheet	-	8
196 Sheet	-	11
20 Wood	8	-
25 Wood	8	-
32 Wood	14	-
20 Hybrid	10	-
5ft Caisson	18	-
8ft Caisson	26	-
11ft Caisson	42	-
13ft Caisson	58	-

All bolts are socket head cap screws with high collar lockwashers.

DANGER

Failure to follow cleaning steps will prevent the bolts from fully tightening, causing the clamp bolts to break. If the clamp bolts break, check the machined surfaces with a straight edge to make sure they are flat. Replace all bolts, not just those broken, when reinstalling.

NOTICE

Do not tighten bolts until all bolts have been engaged.

Do not tighten bolts while the clamp/attachment is hanging from the vibrator.

To Place a Caisson Clamp on a Beam:

1. Loosen the wedges by turning the wedge screws counter clockwise. One face of the clamp will bear the TIGHTEN label. Tighten or loosen the wedge screw by turning only this side.
2. When the wedge screw is loosened, free the wedge by striking the face of the wedge screw with a sledgehammer.
3. Slide the caisson clamp onto the beam and into position. Ideally all clamp buckets will face outwards.
4. Once at the desired separation, partially tighten the wedge screw with a wrench or impact driver. If using an impact driver *do not* tighten the nuts all the way.
5. Finish tightening the nuts with a 20lbs sledgehammer and 2" lug wrench.
6. Install safety bolts onto the ends of the caisson beam with nuts on the bottom. These will help prevent the caisson clamps from falling off during adjustments and operation.



Caisson TIGHTEN label appears on one side of the clamp above the wedge screws.

Hooking up a Vibro to the Power Unit

As shipped, most vibrators will be laid over with their hoses bundled on top. To run the clamp, the two 3/8" clamp lines from the vibro will need to be hooked up.

1. Check pressures at the power unit. If there is any pressure in the clamp CLOSE line, turn on the power unit and set the clamp switch to OPEN. Return it to neutral and continue with the procedure.
2. Clean both ends of the clamp QD's thoroughly.
3. Hook up the QD's. Trace the lines to ensure CLOSE is joined to CLOSE. Alternatively, set the QD's to either port then follow the Bleeding Lines procedure on the next page.



Power Unit quick disconnects, OPEN on left and CLOSE on right.

NOTICE

Any contaminants that enter the hydraulic fluid will severely reduce the life of the components.

OPERATORS INFORMATION

Bleeding and Hooking Up Vibro Lines

When the vibrator and hydraulic clamp are shipped with all hoses attached the hoses are usually full of oil and may be used immediately. Two hoses should connect the vibrator and each clamp.

This procedure should be performed as part of routine maintenance. Other reasons to bleed the hydraulic clamp are if a hose is connected at the job site, a damaged clamp hose replaced, or an old unit returned to service.

1. Clean all clamp bucket fittings with ether.
2. Start and warm up the power unit. Run the unit at a low idle.
3. Set clamp switch to CLOSED.
4. When the clamp is fully closed set clamp switch to Neutral.
5. Disconnect the hose at the clamp OPEN side.
6. Cap the OPEN port on the clamp bucket.
7. Place loose hose end in an empty container and set the clamp switch to OPEN for 30 seconds.
8. Set the clamp switch to Neutral and reattach the clamp OPEN hose.
9. Set the clamp switch to OPEN.
10. When the clamp is fully open set switch to Neutral.
11. Unplug the clamp CLOSE hose. Cap the CLOSE port on the clamp bucket.
12. Place the loose hose end in an empty container and set the clamp switch to CLOSE for 30 seconds.
13. Set the clamp switch to Neutral. Plug the clamp CLOSE hose back into the clamp bucket.

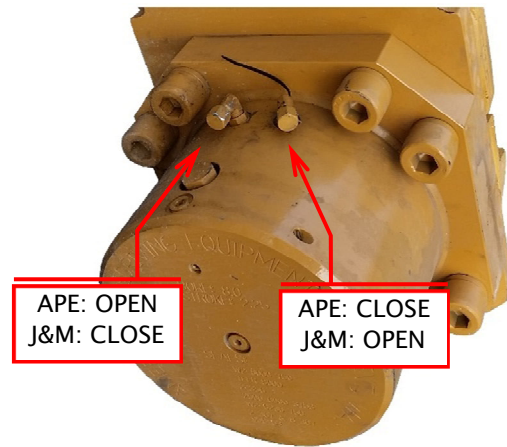

OPEN/CLOSE ports on caisson and sheet clamps.

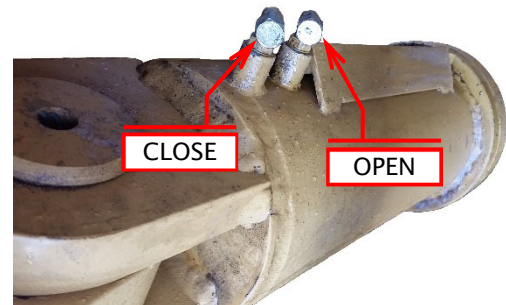

OPEN/CLOSE ports on wood clamp cylinders

WARNING

NEVER tighten or loosen connections while there is oil running through the clamp system. High pressure oil could spray and cause serious injury.

NOTICE

Any contaminants that enter the hydraulic fluid will severely reduce the life of the components.

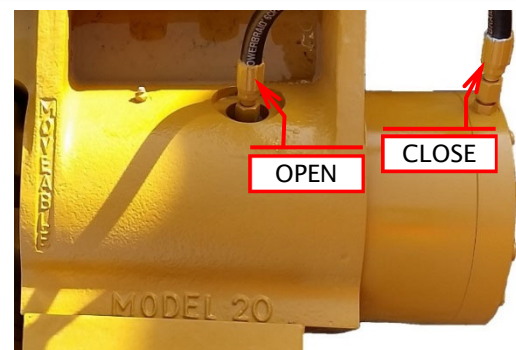

OPEN/CLOSE ports on Model 20 sheet clamp

Changing Clamp Jaws and Pile Guides

For some jobs it will be necessary to switch out the jaws on the clamp. Ensure that the vibrator and/or clamp are laid over and supported by dunnage before beginning. For added safety disconnect the drive hoses from the power unit.

To change the fixed jaw on sheet and caisson clamps:

1. Turn on and warm up the power unit. Bleed clamp lines as described previously in this chapter if necessary before beginning the rest of the procedure. When the power unit is warmed up OPEN the clamp jaw fully.
2. Remove the bolts on the fixed jaw. If force is required to loosen the fixed jaw from the clamp body, avoid damaging the jaw teeth.
 - a. *If also installing moveable jaw, pause procedure here and move to that task.*
3. Insert new bolts according to the specifications on this page. Ensure bolts have an appropriate amount of anti-seize and note its K value.
4. Hold jaw against bolts and engage threads by hand. Once all bolts are engaged run them in without fully tightening.
5. Fully CLOSE the clamp. Maintain clamp pressure on the jaws.
6. Tighten bolts to the torque specifications given on Pg. 90.

To change the moveable jaw on sheet clamps:

1. Turn on and warm up the power unit. Bleed clamp lines as described previously in this chapter if necessary before beginning the rest of the procedure.
 - a. If a fixed sheet jaw is already installed on the unit, remove it before proceeding. Do not reinstall the fixed jaw until the moveable jaw is fully installed.
2. When warmed up CLOSE the clamp jaw fully.



DANGER

KEEP LIMBS AND TOOLS CLEAR OF CLAMP JAWS WHILE CLAMP IS ENERGIZED.

Bolt specifications for fixed jaw replacement:

- Model 20, 50, 150, and 200 Sheet: 2 SHCS 1.0-8x9.0" bolts each with a 1" HCLW.
- Model 400 Sheet: 2 SHCS 1.0-8x11.0" bolts each with a 1" HCLW.
- J&M Model 126 Sheet: 2 SHCS 1.0-8x4.0" bolts each with a 1" HCLW.
- J&M Model 196 Sheet: 2 SHCS 1.0-8x4.5" bolts each with a 1" HCLW.
- Model 80b Caisson: 2 SHCS 5/8-11x2.75" bolts each with a 5/8" HCLW.
- Model 100 Caisson: 2 SHCS 5/8-11x3.75" bolts with a 5/8" HCLW.
- Model 200 Caisson: 2 SHCS 5/8-11x4.0" bolts with a 5/8" HCLW.

OPERATORS INFORMATION

3. Insert two equally sized metal spacers between the rear of the moveable jaw and the clamp body so that the moveable jaw will receive even resistance when the clamp is set to OPEN.
4. OPEN the clamp. The roll pin between the moveable jaw and the clamp plunger should shear.
5. Remove the moveable jaw once the clamp is fully OPEN.
 - a. If the roll pin did not fully shear, CLOSE the clamp and repeat steps 2 through 4 with larger metal spacers.
6. CLOSE the clamp. Use a hammer and pin to remove the remains of the roll pin from both the moveable jaw and the clamp plunger.
7. Align the new moveable jaw on the clamp plunger. Some adjustment of clamp plunger position may be needed to align the holes.
8. Insert a new roll pin into holes and tap down until it is exactly halfway, with equal depths extending into the cylinder plunger on each side of the jaw.
9. OPEN and CLOSE the clamp to make sure it has a full range of motion.

To install sheet and dunce pile guides:

1. Remove any guides that are not needed.
2. Clean bolt holes with wire brush and compressed air. If threads are rusted use a tap to clear them.
3. Bolt specifications are listed in the pop out box. Use appropriate anti-seize and note the K value.
4. Align guide on the holes and engage all bolts. Dunces guides may only be fitted on the fixed jaw side.
5. Once all bolts are started, tighten them in a star pattern to the torque specified in the torque chart on Pg. 90.



DANGER

KEEP LIMBS AND TOOLS CLEAR OF CLAMP JAWS WHILE CLAMP IS ENERGIZED.



Bottom view of roll pin hole on moveable jaw.

Bolt specifications for dunces and sheet pile guides:

- Model 20, 50, 150, and 200 Sheet clamp pile guides: 4 SHCS 1.0-8x3.0" bolts each with a 1" HCLW.
- Model 50 and 150 dunces spikes: 4 SHCS 1.0-8x2.0" bolts each with a 1" HCLW.
- Model 400 Sheet pile guide: 4 SHCS 1.0-8x4.0" bolts each with a 1" HCLW.
- J&M Model 126 and 196 Sheet pile guides: 4 SHCS 1.0-8x2.5" bolts each with a 1" HCLW.

To install square or circular jaws on wood clamps:

1. While the clamp is still upright, loosen the bolts on the fixed jaw.
2. Turn on and warm up the power unit. Bleed clamp lines as described previously in this chapter if necessary before beginning the rest of the procedure.
3. Lay the clamp and/or vibrator over so that it securely rests on dunnage.
4. OPEN the clamp jaws fully. Secure the arm with wedges.
5. Follow these steps to remove the moveable jaw.
 - a. Two bolts will be exposed at the rear. Loosen these but do not remove them.
 - b. Turn the moveable plate with a long bar and secure it open with wedges. Remove the bolts that are exposed.
 - c. Return the plate to a neutral position. Secure the teeth from below so that they won't fall when the final bolts are removed then remove the bolts and jaw.
6. Position the replacement jaw, supporting it as necessary, and insert the rear bolts. Bolt specifications are given in the pop out box. Make sure they have fresh anti-seize, noting the K value. Engage the bolts without fully tightening them.
7. Pry open the jaw and secure it as in step 6b. Insert and tighten all remaining bolts to the torques specified on Pg. 90.
8. Remove bolts on the fixed jaw. Position replacement jaw and engage bolts by hand. Use anti-seize, noting the K value. Bolt specifications are noted on this page.
9. When all fixed jaw bolts are hand tight, remove the wedges on the moveable arm.
10. Stand the vibrator and/or clamp upright and tighten the fixed jaw bolts to the torque specified on Pg. 90.



WARNING

BEWARE OF SHEAR AND PINCH POINTS, ESPECIALLY BETWEEN THE MOVEABLE ARM AND THE CLAMP FRAME GAPS.



DANGER

The hydraulic cylinder is NOT designed to hold pressure in this position. Oil may drain from the cylinder, gradually releasing the moveable arm.

Bolt specifications for wood clamp moveable jaw:

- Model 20, 25, and 32 Wood clamp moveable jaw: 6 SHCS 1.5-6x4.0" bolts each with a 1.5" HCLW.

Bolt specifications for wood clamp fixed jaw:

- Model 20 Wood clamp fixed jaw: 6 SHCS 1.5-6x6.5" bolts each with a 1.5" HCLW.
- Model 25 and 32 Wood clamp fixed jaw: 6 SHCS 1.5-6x3.25" each with a 1.5" HCLW.



WARNING

Use caution when removing the wedges. Abrupt motion of the arm is possible and could result in property damage or serious injury.

OPERATORS INFORMATION

Clamping Force Calculations

An accurate calculation of the clamps gripping force is essential for safe operation. The values provided in the specifications pages are accurate only for a specific pressure setting and it may be necessary to calculate a new one on the job site.

- Cylinder diameters can be found on the specifications pages.
- Use the clamp CLOSE pressure value displayed by the power unit, which can be adjusted by changing the clamp relief valve setting as described in the power unit manual.
- The 20" Hybrid and C102 Wood Clamps use two pistons closing from the rod end. For these clamps only, Cylinder Area = 20.32 in² (13110 mm²). Carry out the rest of the equations as normal.



Power unit clamp CLOSE dial as seen beside the power unit control panel. Pressure measured in psi and bar.

Formulas



The true cylinder force will always be lower than the theoretical cylinder force. The true cylinder force will depend on the coefficient of friction between the jaw teeth and the pile.

$$\text{Cylinder Area} = 0.7854 \times \text{Cylinder Diameter}^2$$

$$\text{Cylinder Force (lb)} = \text{Cylinder Area (in}^2\text{)} \times \text{Clamp CLOSE Pressure (psi)}$$

(OR)

$$\begin{aligned} \text{Cylinder Force (kN)} &= \frac{\text{Cylinder Area (mm}^2\text{)} \times \text{Clamp CLOSE Pressure (Bar)}}{1,000} \\ &= \frac{\text{Cylinder Area (mm}^2\text{)} \times \text{Clamp Close Pressure (KPa)}}{1,000,000} \end{aligned}$$

Greasing the Clamp

At the start of each work day the clamp cylinder should be greased.

1. Make sure the clamp OPEN and CLOSE ports are tightly attached.
2. Clean the grease-zerk. If the grease-zerk is blocked, replace it.
3. Run the clamp cylinder back and forth while applying grease to the grease-zerk. **Use NLGI Grade 2 EP2 or equivalent.**
4. Continue to apply grease and run the clamp until grease escapes around the plunger near the jaws.



Grease-zerks are on the clamp cylinder near the jaws.

NOTICE

Do not use a pneumatic gun to apply grease. Excessive air bubbles may be introduced to the space around the clamp plunger.

Clamp Thermal Relief

Heat from the environment or vibro operation will cause hydraulic oil in the clamp to expand. This is a hazard to personnel and the equipment.

- Do not leave the clamp pressurized during downtimes longer than 1 hour.
- Every 30 to 45 minutes of work, stop and relieve clamp pressure. Re-clamp before resuming work.



Extreme hydraulic pressure can crack the clamp cylinder casing, burst hoses, or rupture the clamp seal cartridge. All may cause severe injury or death.

Do not attempt to relieve clamp pressure while vibro is in drive forward.

Check Valve Test

Many clamp pressure loss issues are related to a faulty check valve.

1. While clamp is hooked up, turn on and warm up power unit. Leave it on a low idle.
2. Remove the OPEN side hose at the clamp.
3. While taking precautions against oil spray and leakage, set clamp switch to CLOSE.
4. When clamp is fully closed check OPEN side port for bypass oil. A drip rate of roughly one drop per five seconds is acceptable.
5. If drip rate is low reattach the OPEN hose.



USE CAUTION, HIGH PRESSURE OIL MAY SPRAY FROM PORT.

DO NOT ATTEMPT TO TOUCH THE PORT OR REATTACH THE HOSE IF OIL IS SPRAYING.

- a. If the oil is streaming or spraying do not attempt to attach the hose. Allow the leak to relieve the CLOSE side pressure and order a new check valve.

OPERATORS INFORMATION

Worn Jaw Check

Periodic checks of the sheet clamp jaws are required to ensure safe operation of the vibro. Follow this procedure on the first day of work and weekly after. More frequent checks will be required in abnormal operating conditions.

1. If the clamp jaws are not fully open, turn on the power unit and open them. Turn off the power unit and keep it off for the rest of the procedure.
2. Measure between teeth valleys and peaks.
3. Teeth can be worn up to half of their original depth of $5/16"$ or 8mm if the teeth are evenly worn. Depth less than $5/32"$ or 4mm requires replacement of the clamp jaw.
4. All teeth must engage the pile. If values fall within the acceptable range but show uneven levels of wear, especially on the bottom few teeth, replace the jaw.
5. Also ensure that, at the present level of tooth wear, there is clearance in the concave region of the sheet clamp jaws to allow the inner-lock of the sheet piles.

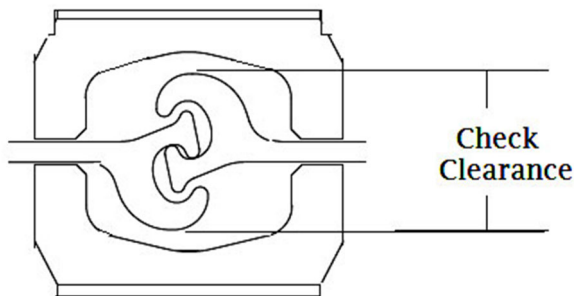

Visualization of internal clearance of sheet jaws.

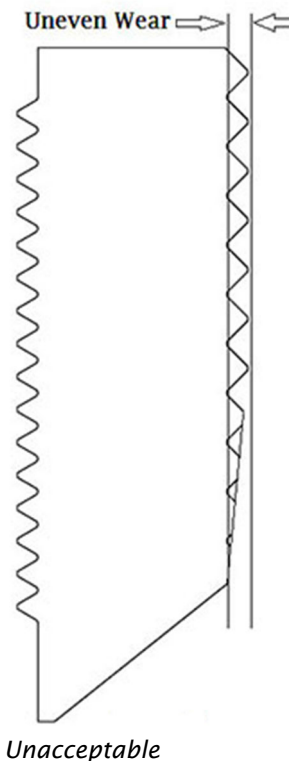
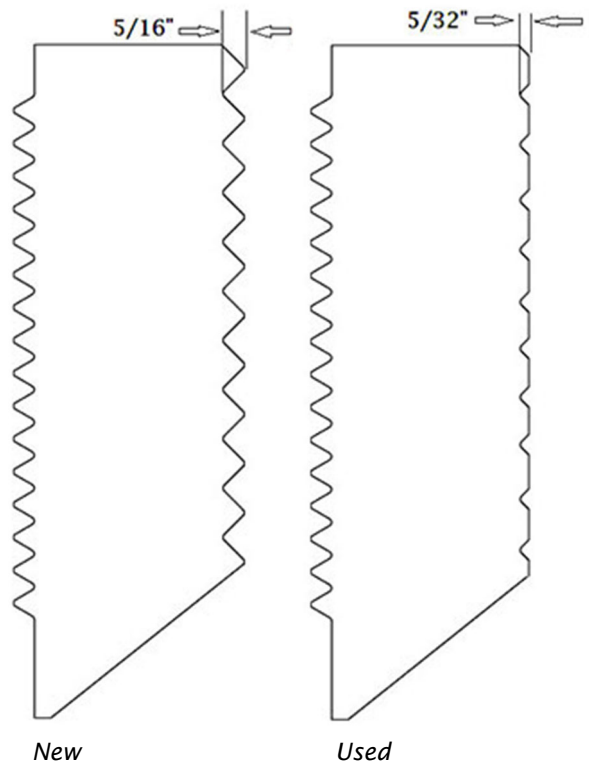

Unevenly worn jaws in need of prompt replacement.

Fluid Cleanliness

It is imperative that the hydraulic fluid is kept clean to a minimum ISO Code 17/15/11. Bulk oil does not typically meet the cleanliness standards required by APE equipment.

See attached document Understanding ISO Codes on Pg. 91 and Warranty regarding fluid cleanliness.

Storage

During short-term storage of the clamp, the following steps should be taken:

- Ensure the clamp has been freshly lubricated.
- Fully OPEN the clamp cylinder.
- Disconnect hoses.
- Cover any pressure openings and open threaded holes with suitable caps.
- Protected the unpainted surfaces from dirt and moisture. **DO NOT PAINT OVER GREASE-ZERK.**
- Do **NOT** store the clamp in an area with substances that have an aggressive corrosive nature, i.e. solvents, acids, alkalis, or salts.

For long-term storage (over 9 months) the following additional actions are recommended:

- Repair any damage to surface paint before item is stored.
- Protect the unpainted surfaces with suitable anti-corrosion treatment such as CRC SP-350, CorrosionC corrosion inhibitor, or WD-40 Long Term Corrosion inhibitor.
- Make sure the clamp hydraulic components are completely full of clean hydraulic fluid.

If these instructions are followed the clamp may be stored for approximately 2 years. However, as storage conditions do have a significant effect, all suggested time frames should only be considered as guide values.

NOTICE

New hydraulic fluid is NOT clean oil.

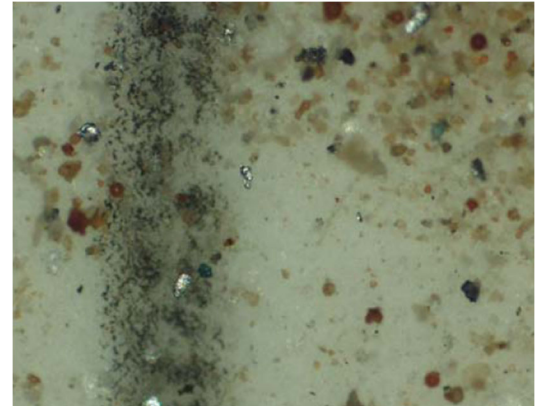

New hydraulic oil under microscope.

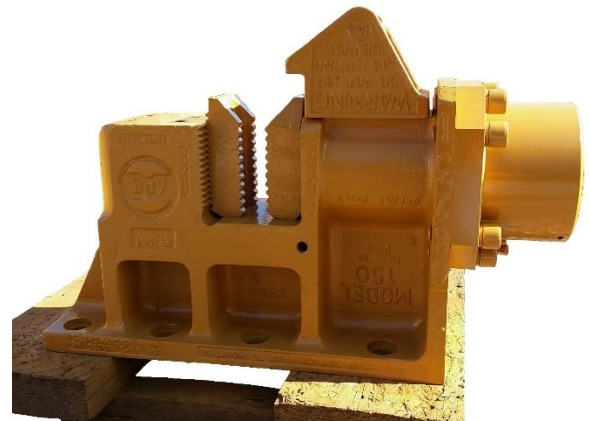

150 Sheet clamp painted for storage. Machined surface on bottom will still require protection.

MAINTENANCE / TROUBLESHOOTING

Daily Checklist

At the beginning of each shift, check the following:

- Visually inspect all bolts, nuts and screws, including those that mount the clamp to the gearbox. Vibration loosens bolts, check carefully.
- Visually inspect clamp jaws and teeth for cracking.
- Tighten bolts holding gripping jaws to the clamp.
- Grease clamp piston in accordance with the procedure found on Pg. 37.
- Visually inspect all hydraulic fittings for leaks.
- Visually inspect hoses for damage or cuts that might cause hose failure during operation.
- After starting power unit make sure that hydraulic hoses are hanging freely. Check for leaks.
- Close clamp jaws. Ensure green clamp switch lights come on.

NOTICE

Check the entire unit prior to and during set up each day or at the beginning of each shift.



DANGER

Vibration loosens bolts. Check them thoroughly.

NOTICE

It is absolutely imperative that no dirt or other impurities be permitted to contaminate the hydraulic fluid. Any contamination will drastically shorten the life of the high-pressure hydraulic system.



Metal hose braiding badly frayed, rendering the hose unsuitable for use.

Long Term Maintenance

Non-Daily Maintenance Tasks		
Weekly	Six months	Yearly
<ul style="list-style-type: none"> Unhook clamp lines and follow Bleeding Lines procedure on Pg. 32. Follow Worn Jaw Check procedure on Pg. 38. 	<ul style="list-style-type: none"> Replace fixed and moveable clamp jaws. Use dye penetrant inspection to check clamp body for cracking around clamp jaws. 	<ul style="list-style-type: none"> Replace clamp line hoses. Examine O-rings for wear.

Preventative maintenance includes normal servicing that will keep the clamp in peak operating condition and prevent unnecessary trouble from developing. This servicing consists of periodic lubrication and inspection of moving parts and accessories of the unit. Lubrication is an essential part of preventative maintenance controlling the useful life of the clamp.

To prevent minor irregularities from developing into serious conditions that might involve shutdown and major repair, several other services or inspections are recommended. The purpose of these services or inspections is to assure the uninterrupted operation of the unit.

The intervals given in the schedule are based upon normal operation. Perform these services, inspections, etc., more often as needed for operations under abnormal or severe conditions.

- When the average temperature is above 80°F (26°C) or below -10°F (-23°C) reduce the service time intervals by one half of those specified in the chart.
- When operating in the presence of dust or sand reduce service time intervals by one-half of those specified in the chart.
- When operating more than 12 hours per day, reduce the service time intervals by one-half of those specified.
- For extended inactive periods the clamp should be run and greased once a week.

NOTICE

Thoroughly clean all lubrication ports and fittings along with their surrounding surfaces before servicing.

Prevent dirt from entering with lubricants and hydraulic oil.

MAINTENANCE / TROUBLESHOOTING

Problem Identification

Symptom	Possible Cause	Remedy
<p>Clamp light doesn't illuminate when pressure is at or above 4500 PSI.</p> <p><i>OR</i></p> <p>Clamp is losing pressure over time, or clamp light doesn't illuminate when pressure is below 4500 PSI.</p>	Relief valve set too low.	Release clamp pressure and disconnect QD's. Test clamp pressure at power unit console. If below 4500 PSI reference your power unit manual for the procedure on adjusting clamp pressure.
	Quick disconnects not fitted properly.	Release clamp pressure. Remove, inspect, clean, and reattach QD's.
	There is an electrical fault.	-Check lights on both power unit console and pendant for failed bulbs. -Check electrical connections for corrosion or broken wires.
	Hoses are leaking.	Depressurize clamp and check hoses and QD's for leaks. Immediately halt work and replace any hose found to leak.
	Faulty clamp check valve.	Follow the Check Valve Test procedure on Pg. 37.
	Seals are leaking internally.	Check clamp rod for bad O-rings.
<p>Opening and closing clamp jaws seems spongy or slow.</p>	Quick disconnects not fitted properly.	Release clamp pressure and tighten QD's. It may be necessary to clean QD's of dirt or rust first.
	The clamp hoses have air in them.	Follow the procedure on Pg. 32 to bleed the clamp hoses.
	Oil leaks are slowing the clamp.	Inspect hoses and clamp seals, replacing if needed. Follow Check Valve Test procedure on Pg. 37.
	The plunger shaft is not properly lubricated or needs cleaning.	Remove the moveable jaw from the clamp according to the instructions given on Pg. 33. Inspect the plunger shaft and check for lubrication or debris build up. Clean the shaft if needed then lubricate using the grease-zerk on the clamp body.
<p>Clamp CLOSE pressure rises and falls repeatedly.</p>	<p>Leaks, internal or external, are triggering the clamp CLOSE pressure switch.</p>	Examine hoses, QD's, and power unit clamp manifold for leaks.
		Follow Check Valve Test procedure on Pg. 37.

MAINTENANCE / TROUBLESHOOTING

Symptom	Possible Cause	Remedy
Clamp won't close or open when the clamp switch is engaged.	Vibrator is running.	The clamp won't open while the vibrator is in operation. To open the clamp, stop the vibrator.
	Quick disconnects not fitted properly.	Release clamp pressure and tighten QD's.
	Hoses are not properly routed.	Toggle the clamp switch to see if the desired operation occurs.
	Diesel engine not running.	Start the power unit and allow clamp pressure to build.
	Leaks are allowing oil to bypass the clamp circuit.	Check for leaks and faulty components as with clamp lights failing to illuminate.
	There is an electrical fault.	Check for the following: -Defective clamp switch. -Broken or loose wire in the pendant or pendant cable. -Defective OPEN solenoid. -Broken or loose wires. -Defective or sticking clamp timing delay relay.
	Clamp rod seized.	Check lubrication history and examine clamp rod if possible.
Clamp pump is defective.	Check for proper clamp pump operation and replace if needed.	
Bolts attaching clamp to vibrator break.	Mating surfaces not adequately cleaned. <i>OR</i> The bolts were not torqued properly.	Detach the clamp from the vibro and follow the procedure on Pg. 30 for reattaching. Perform the cleaning steps diligently and use all new bolts. Ensure every bolt is properly torqued.
Cracks found in clamp body near jaws.	Clamp body is old or was exposed to excessive force.	Contact APE for advice and evaluation, replacement may be required.
Clamp jaw teeth are cracked.	Clamp teeth are old or were exposed to excessive force.	Replace clamp jaws according to the procedures on Pg. 33.
Hydraulic oil leaking from bucket in area other than clamp line fittings.	Plug or seal on the clamp bucket body has come loose, or a crack has appeared.	Tighten fittings at leak site. If this does not solve the problem or the leak is not coming from a fitting, contact APE. <i>DO NOT SERVICE EQUIPMENT WHILE CLAMP IS UNDER PRESSURE.</i>

MAINTENANCE / TROUBLESHOOTING

Hydraulic Schematics

These schematics are for use with all APE caisson and sheet clamps (except Model 20). The Model 20 and Wood Clamps link directly from the OPEN/CLOSE ports to the clamp cylinder. Refer to your power unit manual for adjusting the power unit clamp circuit pressure.

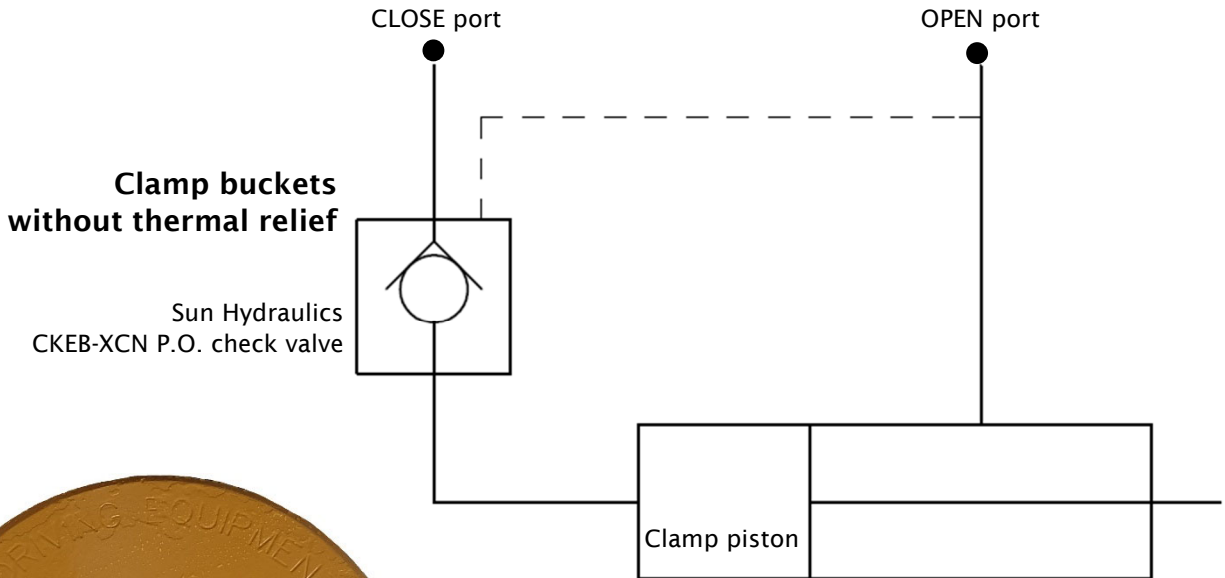

Thermal relief indicated by 2nd off-center plug on clamp bucket face

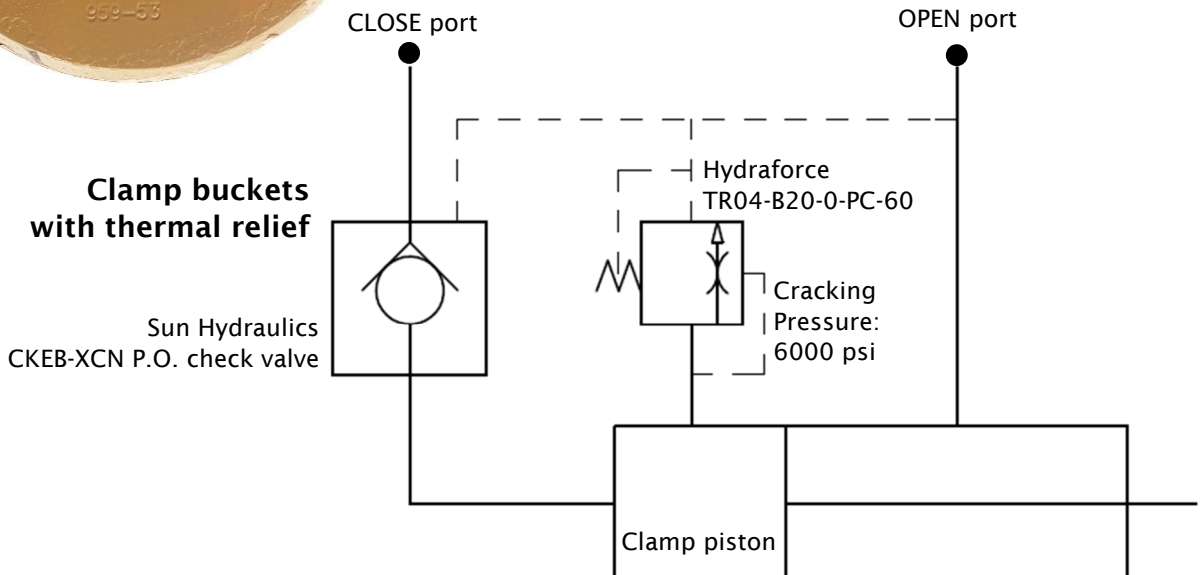

MAINTENANCE / TROUBLESHOOTING

This schematic is appropriate for both the C102 and Hybrid 20 clamps.

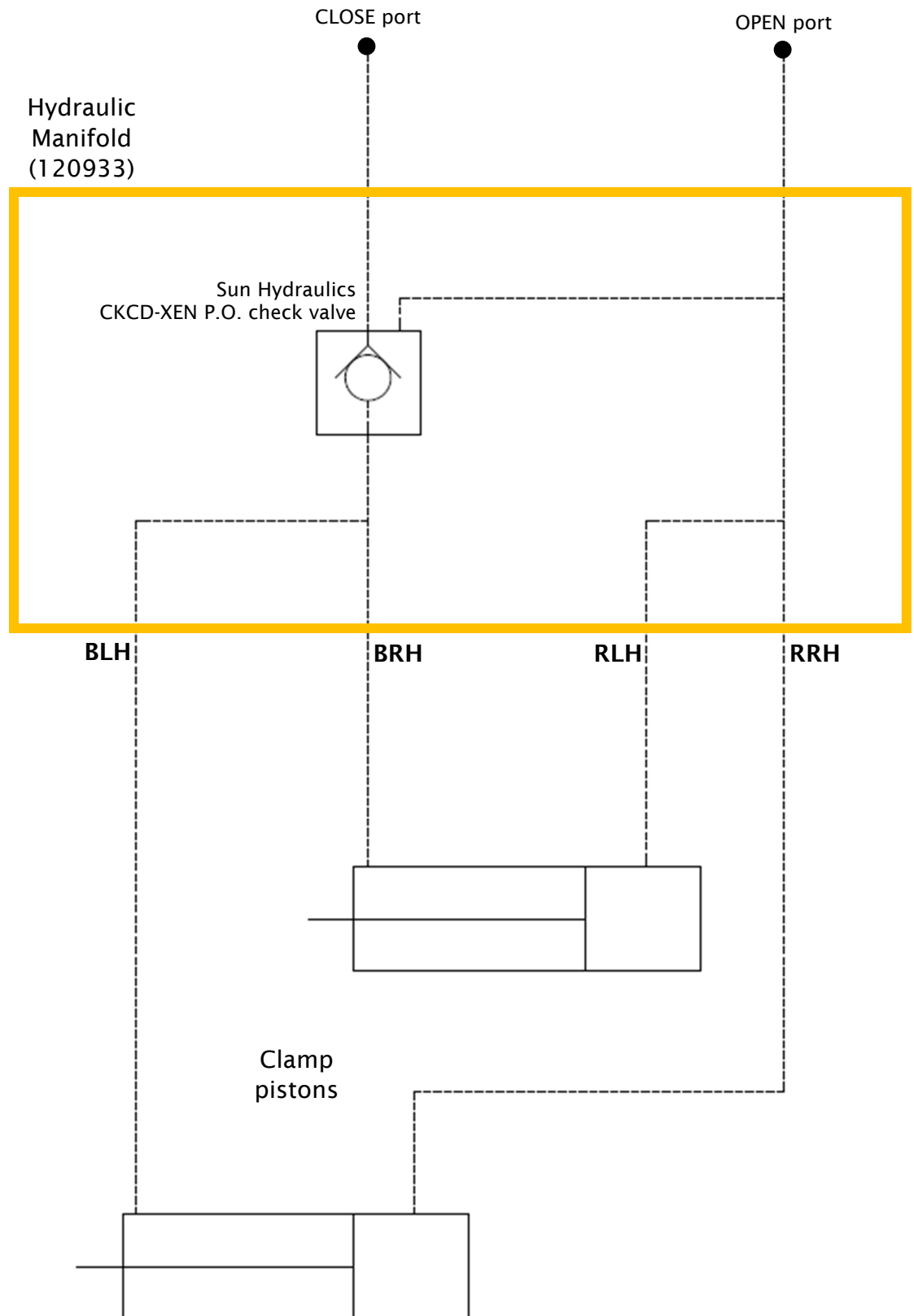

REPLACEMENT PARTS / BOM

Ordering Parts

When ordering parts be sure to include the model and serial number of the unit or component. The serial number may be located by referring to Labels on Pg. 28. Confirm all telephone orders in writing immediately to avoid duplicating shipment.

ORIGINAL EQUIPMENT: Where component serial numbers are given, these apply only to equipment and components originally furnished with the unit. Where equipment has been changed or upgraded these numbers may not be an adequate description.

SHIPMENT: State to whom shipment is to be made and method of shipment desired, otherwise our own judgment will be used.

SHORTAGES: Claims for shortages or errors should be made immediately upon receipt of parts. No responsibility will be assumed for delay, damage, or loss of material while in transit. Broken, damaged, or lost material should be refused, or a full description made of damage or loss to the carrier agent on the freight or express bill.

RETURN OF PARTS: If for any reason you desire to return parts to the factory or to any distributor from whom these parts were obtained, you must first secure permission to return the parts.

Shipping instructions will be given along with this permission. A ten percent handling charge must be assessed against the returned shipment unless an error is made by the factory or by the distributor when filling your order.

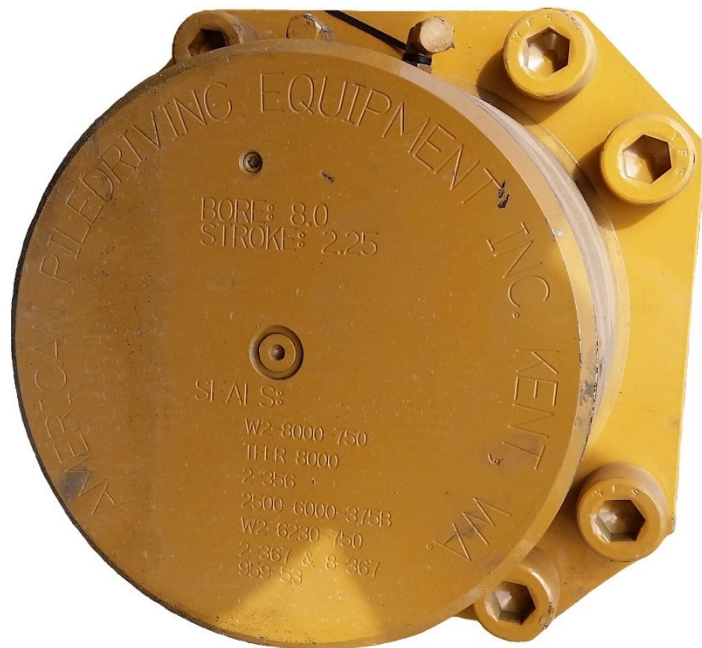

Most clamp buckets will have seal information printed on the bucket face.

Hose and Fitting Replacement

The Hose Description Code is a 24-digit number enabling easier and quicker identification whenever a hose replacement is desired. The key below explains the structure of the coded number in detail.

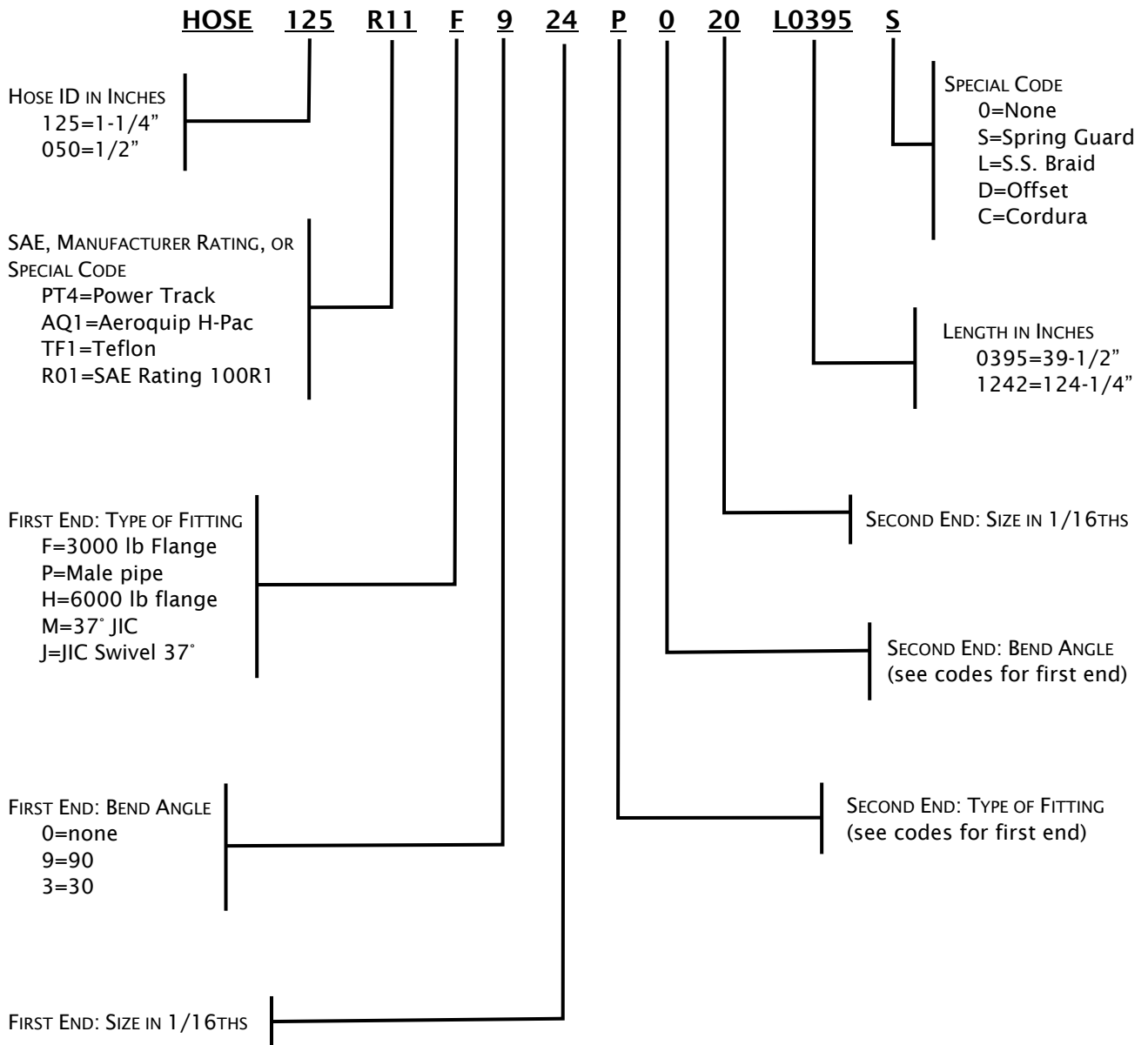



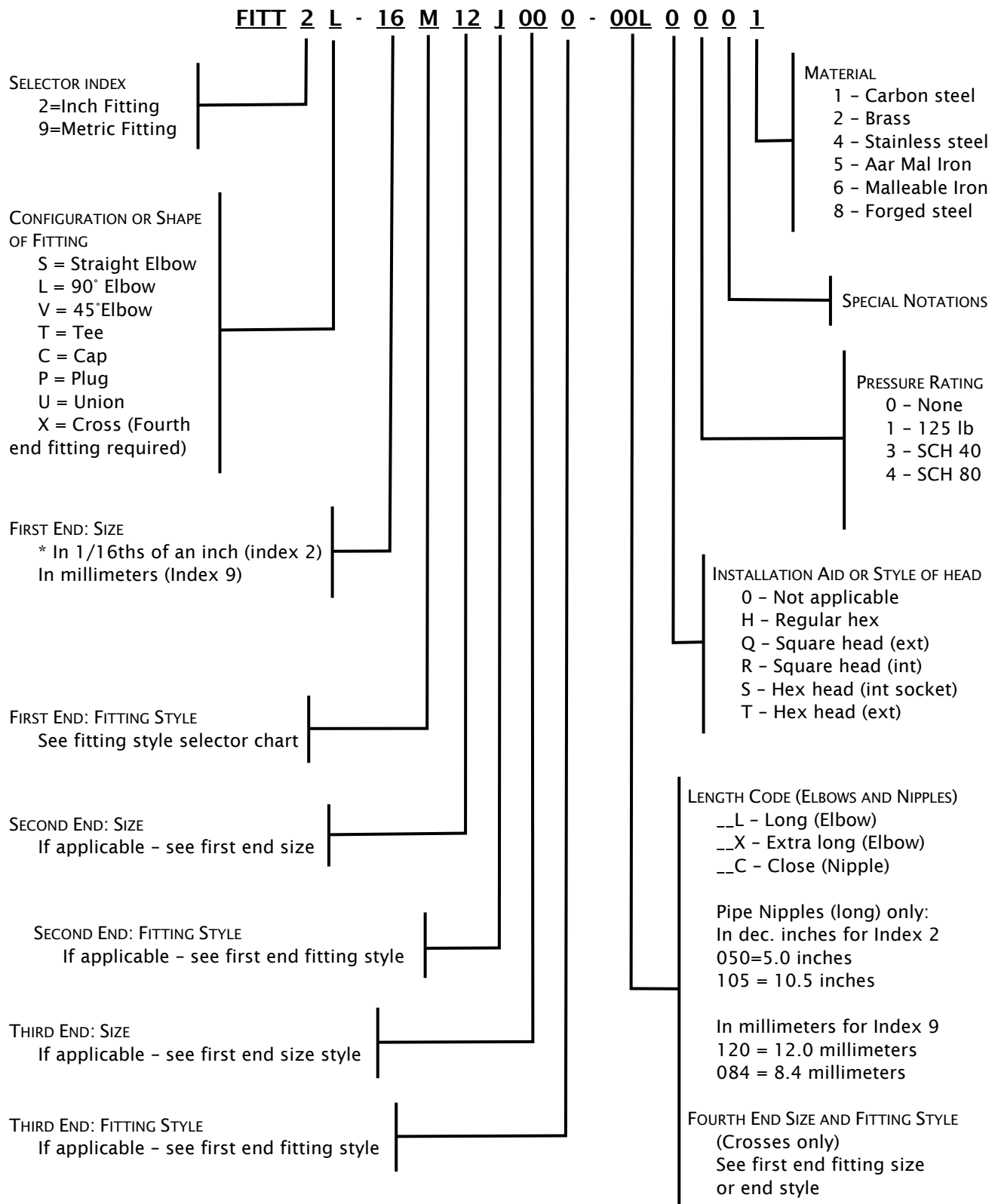

REPLACEMENT PARTS / BOM

Like the Hose Description Code, the Fitting Key described below will aid in the identification and ordering of fittings.

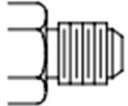
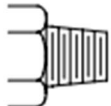
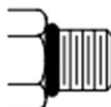
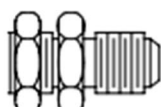

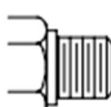
Fitting Style Selector Chart for End Fitting

M		JIC Male 37° Flare
P		Male Pipe NPT
R		SAE Male O-Ring (& Adjustable)
B		JIC Male 37° Flare Bulkhead
D		Male Pipe NPT Swivel
S		BSP Male Pipe

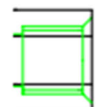
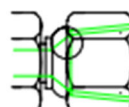
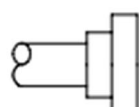
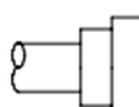
J		JIC Female 37° Flare (& Swivel)
Q		Female Pipe NPTF
K		SAE Female O-Ring
N		Female Pipe NPSM-Swivel
F		Split Flange 3000 PSI Code 61
H		Split Flange 6000 PSI Code 62

Bills of Materials

Model 6 Removeable Clamp

Item	Quantity	APE Number	Description	Manufacturer Information
1	1	1007061	Clamp Body	
2	1	221001	Grease Zerk	Straight 1/8 th NPT
3	1	1006936	Jaw, Model 3/6/9	
4	1		Rod Pin	
	1	1006938	Cylinder Assembly	
5	1		*Rod Seal	2500-2000-375B
6	1	1006934	Hydraulic Gland	
7	1		*Gland Seal	Parker 2-236 O-Ring and 8-236 Backup
8	1	1006935	Cylinder Rod	
9	1		*Piston Seal	Custom Bronze Filled Ring with PTFE
10	1		*Piston Wear Band	W125-03375-0250
11	1	1006933	Cylinder Housing	
12	9	130131	Bolts, Cylinder Mounting	SHCS 3/8-16x4.5x1.5

*Included in Seal or Bolt Kit

Model 6
Removeable Clamp

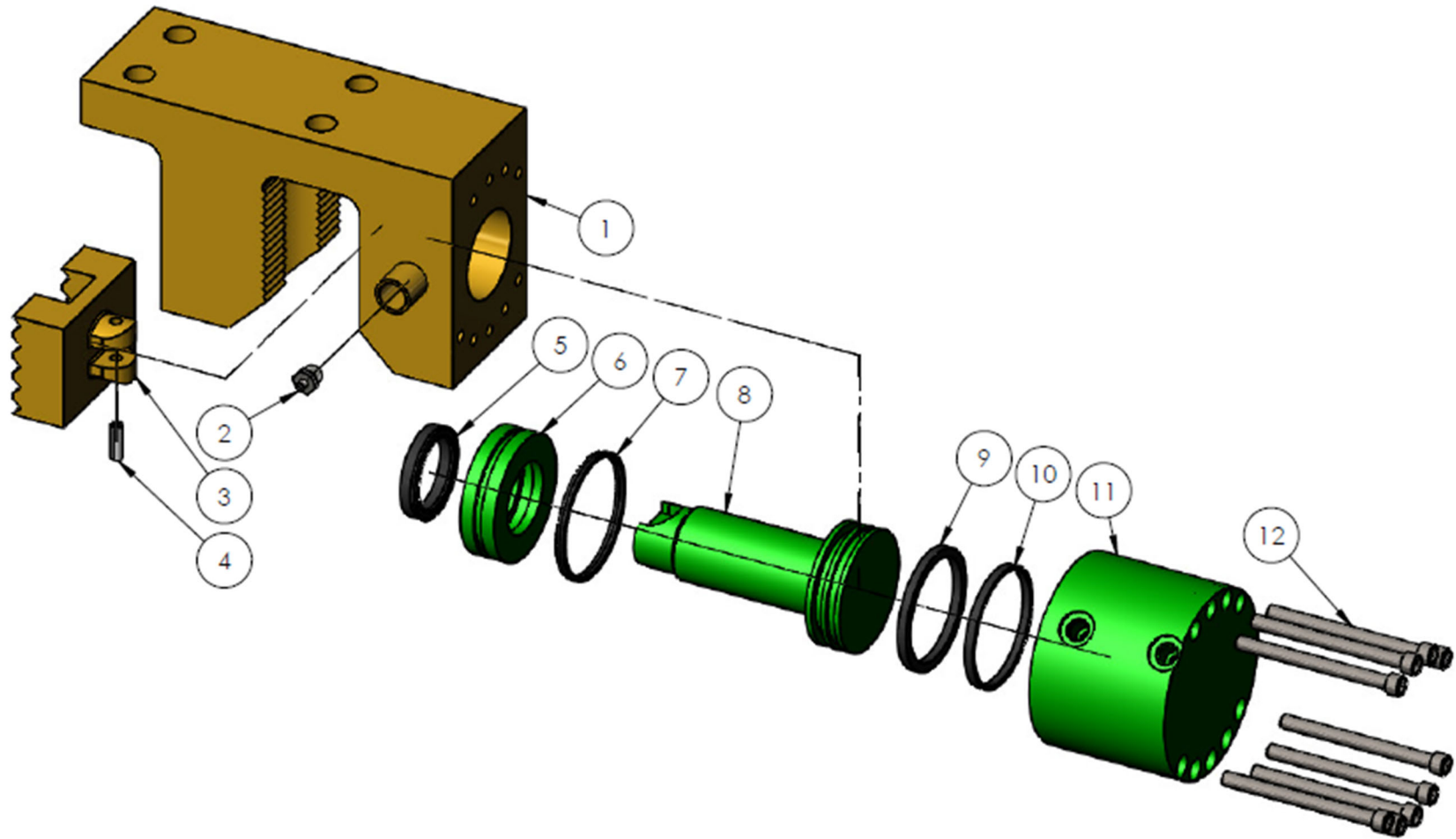

Model 6 and 9 Combined Gearbox and Clamp

Item	Quantity	APE Number	Description	Manufacturer Information
1	1		Vibro Gearbox Type	
		1006659	Gearbox, Model 6	
		1001624	Gearbox, Model 9	
2	1	205005	Moveable Jaw, Model 3/6	
3	1	205006	Fixed Jaw, Model 3/6	
4	1	221001	Grease Zerk	Straight 1/8 th NPT
5	1	205102	Jaw Pin	
	1	1006668	Cylinder Assembly	
6	1	1001643	Cylinder Sleeve Insert, Model 6	
7	1		Rod Seal	250-02.500-375B Polyseal
8	1	1001645	Hydraulic Cylinder Gland, Model 6	
9	1		Gland Seal Backup	8-238 Backup 90 Duro Nitrile
10	1	1002151	Gland Seal	2-238 O-Ring 90 Duro Nitrile
11	1	1001642	Cylinder Rod, Model 6	
12	1		Piston Seal	PS1850-56
13	1		Rod Wear Ring 3-1/2" OD	612-350-025
14	1	1001644	Cylinder Bucket, Model 6	
15	2		SAE Boss 3/8"	
16	10	1003050	Washers, Cylinder Bucket	HCLW 3/8"
17	10	160333	Bolts, Cylinder Bucket	SHCS 3/8-16x1.75
18	6	100027	Washers, Fixed Jaw	HCLW 1/2"
19	6	100163	Bolts, Fixed Jaw	SHCS 1/2-13x1.75

Model 6
Vibro Gearbox and Clamp

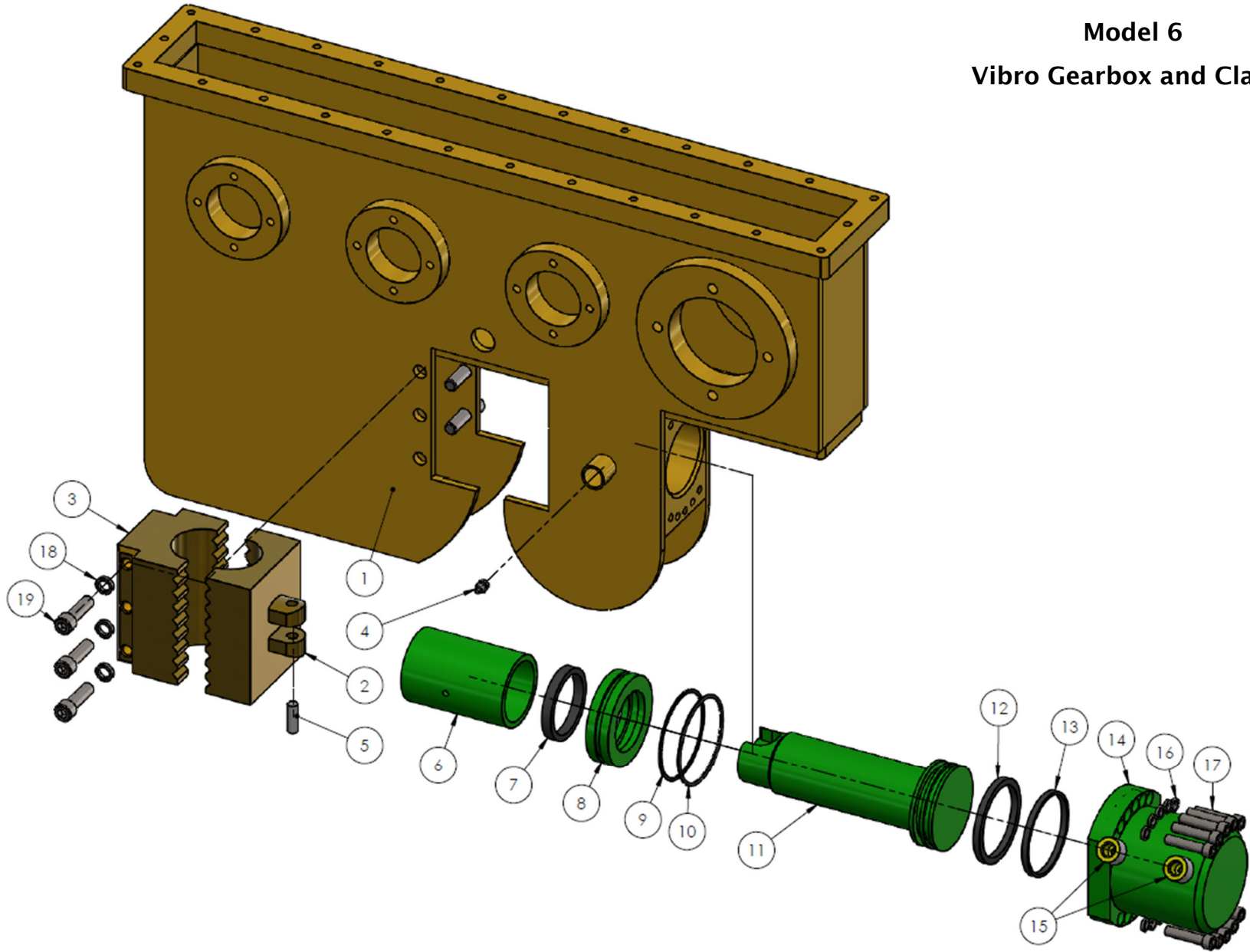

Model 20 Sheet Clamp

Item	Quantity	APE Number	Description	Manufacturer Information
1	1		Model 20 Sheet Clamp Body w/ Nylon Sleeve	
2	1	221014	Fixed Jaw, Single Sheet	
3	1	221008	Moveable Jaw, Single Sheet	
			Double Sheet Jaws	
4	1	221011	Fixed Jaw, Double Sheet	
5	1	221005	Moveable Jaw, Double Sheet	
6	1	221017	Sheet Pile Guide	
7	6	1003063	*Washers, General	HCLW 1.0"
8	4	1003018	*Bolts, Pile Guide	SHCS 1.0-8x3.0" Long
9	2	124206	*Bolts, Fixed Jaw	SHCS 1.0-8x9.0" Long
10	1	221002	Jaw Pin	Spiral Pin 0.75" dia x 3.25" Long
	1	208001	Model 20 Clamp Cylinder Assembly	
11	1	208015	Model 20 Piston Rod	
12	12	100851	Bolts, Cylinder Gland (LOCTITED)	SHCS 0.438-14x1.5" Long
13	1		*Rod Wiper	DT-4000 Wiper U-1003
14	1		*Rod Seal and Backup	568-345 N-7002 and 80-345 Contoured Backup
15	1	208019	Rod End Cap, Cylinder Gland	
16	1		*Rod Wear Ring	Wear Ring 8000-68B
17	2		*Mounting Flange and End Cap Seal O-Ring and Backup	568-248 N-7002 and 80-248 Contoured Backup
18	2		*Piston Wear Ring	Wear Ring 612-500-100
19	1		*Rod and Cap Seal O-Ring	568-238 CMPD N-7002
20	1	208006	Piston Vibro Model 20	
21	1		*Piston Seal	PS1850-80 Bronze PTFE w/ Energizer
22	4	110411	Bolts, Piston Cap	SHCS 0.625-18x1.5" Long
23	1	208017	Cylinder Shell - Model 20	
24	1	208013	Spacer (20 Clamp Cylinder)	
25	1	208021	Cylinder Mounting Flange	
26	12	400043	Bolts, Flange	SHCS 0.5-13x1.5" Long
27	12	160337	*Bolts, Cylinder Mounting	SHCS 0.5-13x5.5" Long
28	2	100053	Straight Fitting, #6 JIC to #6 ORB	FITT2S-06M06R
29	1	221001	Grease-zerk	Straight 1/8" NPT

*Included in Seal or Bolt Kit

Model 20
Sheet Clamp

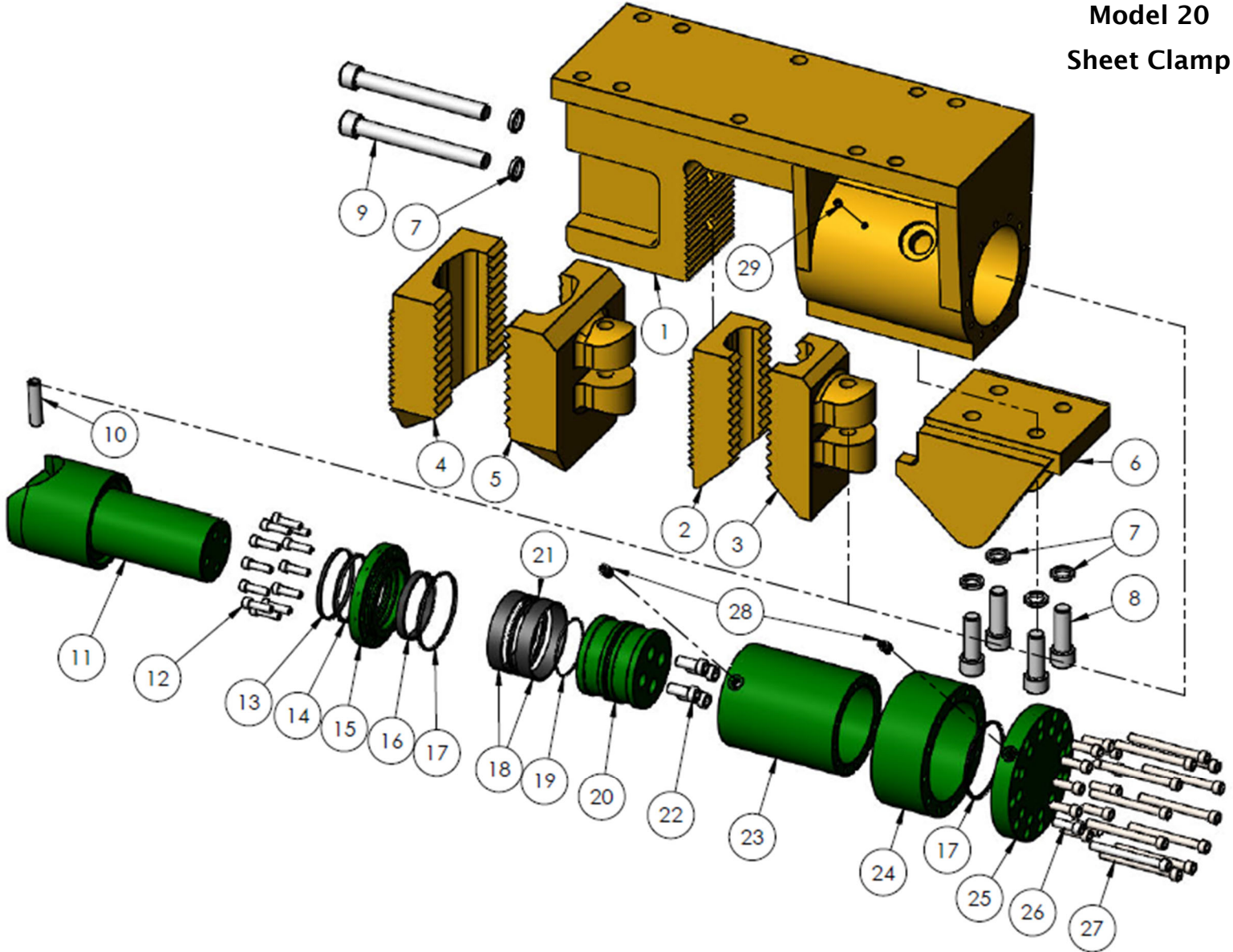

Model 50 Sheet/Dunce Clamp

Item	Quantity	APE Number	Description	Manufacturer Information
1	1		Model 50 Sheet Clamp Body w/ Rod Bushing	
2	1	221011	Fixed Jaw, Double Sheet	
3	1	221005	Moveable Jaw, Double Sheet	
4	1	221017	Sheet Pile Guide	
5	10	1003063	*Washers, Common	HCLW 1.0"
6	4	1003018	*Bolts, Sheet Pile Guide	SHCS 1.0-8x3.0" Long
7	2	124206	*Bolts, Fixed Jaw	SHCS 1.0-8x9.0" Long
			<i>Dunce Clamp Configuration</i>	
8	1	221017	Dunce Pile Guide	
9	4	1003015	Bolt, Dunce Pile Guide	SHCS 1.0-8x2.0" Long
10	1	221006	Moveable Jaw, Single Sheet	
11	1	221015	Dunce Fixed Jaw	
12	1	221002	Jaw Pin	Spiral Pin 0.75" dia x 3.25" Long
	1	222000	<i>Sheet Clamp Cylinder 8" Assembly</i>	
13	12	1003804	*Bolts, Cylinder Gland (LOCTITED)	SHCS 0.625-18x1.0" Long
14	1	1004852	*Rod Wiper	AN Wiper SH959-53
15	1	1004542	*Rod Seal	250-06.000-375B Lubrithane Polyseal
16	1	222004	Front Seal Plate, Cylinder Gland	
17	1	222014	*Rod Wear Band	Wear Guide 06250-0750-125
18	1		*Head Seal O-Ring and Backup	568-367 O-Ring CMPD F-7001 and 80-367 Contoured Backup
19	1	222007	8" Sheet Cylinder Rod	
20	1	1006105	*Piston Seal	PS1850-128 Bronze PTFE w/ Energizer
21	1		*Piston Wear Band	Wear Guide 08000-0750-125
22	1	1001409	8" Hydraulic Cylinder Barrel	
23	2	130057	90 Elbow Fitting, #6 JIC to #6 ORB	FITT2L-06M06R
24	1	222016	P.O. Check Valve	CKEB-XCN
25	8	1000848	*Washers, Cylinder Mounting	HCLW 1.25"
26	8	124204	*Bolt, Cylinder Mounting	SHCS 1.25-12x4.0" Long
27	1	221001	*Grease-zerk	Straight 1/8" NPT

*Included in Seal or Bolt Kit

Model 50
Sheet/Dunce Clamp

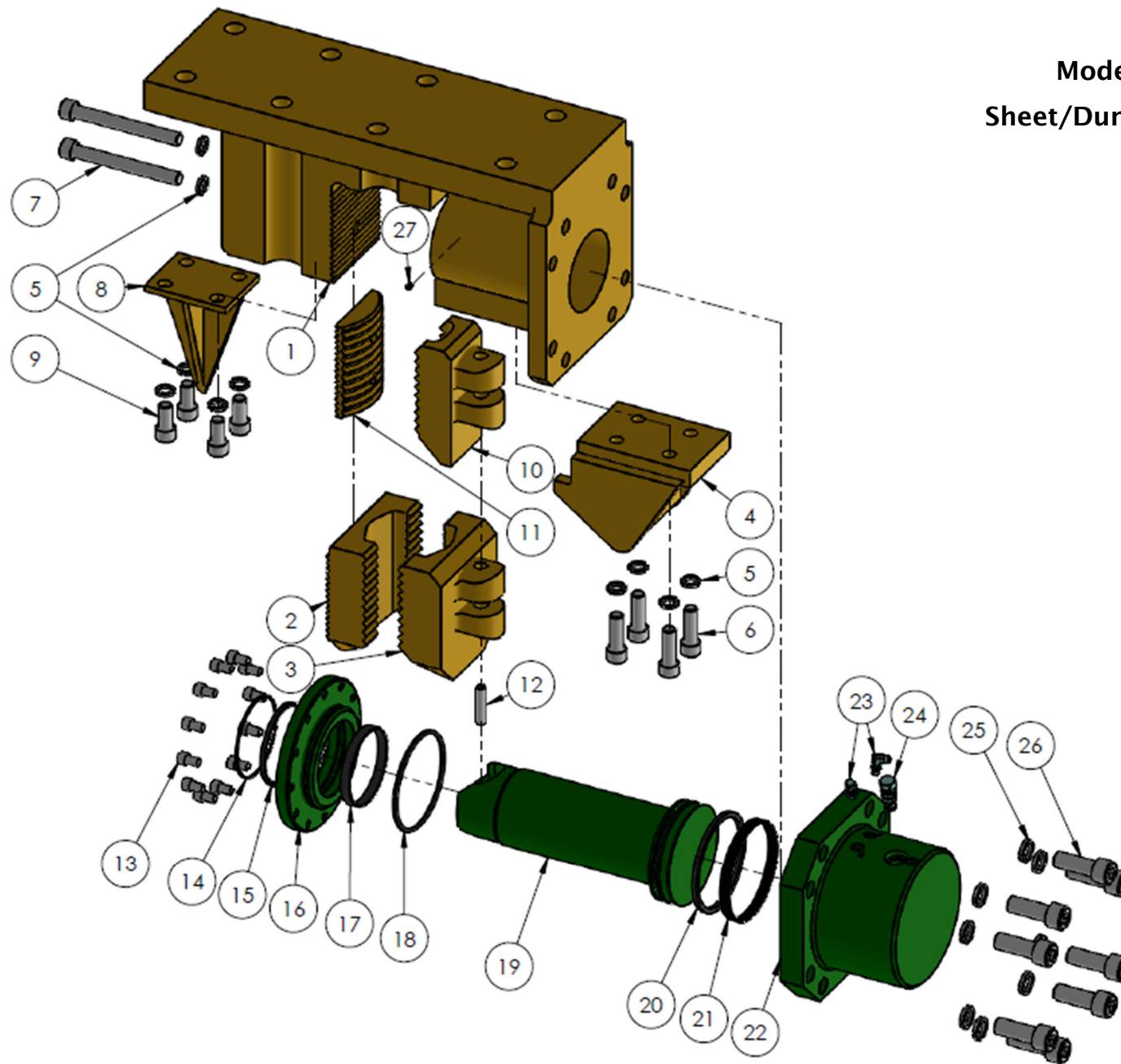

Model 150 Sheet/Dunce Clamp

Item	Quantity	APE Number	Description	Manufacturer Information
1	1	221019	Model 150 Sheet Clamp Body w/ Rod Bushing	
2	1	221011	Fixed Jaw, Double Sheet	
3	1	221005	Moveable Jaw, Double Sheet	
4	1	221017	Sheet Pile Guide	
5	10	124207	*Washers, Common	HCLW 1.0"
6	4	1003018	*Bolts, Pile Guide	SHCS 1.0-8 x 3.0" Long
7	2	124206	*Bolts, Fixed Jaw	SHCS 1.0-8 x 9.0" Long
			<i>Dunce Clamp Configuration</i>	
8	1	221017	Dunce Pile Guide	
9	4	1003015	Bolts, Dunce Pile Guide	SHCS 1.0-8 x 2.0" Long
10	1	221006	Moveable Jaw, Single Sheet	
11	1	221015	Dunce Fixed Jaw	
12	1	221002	Jaw Pin	Spiral Pin 0.75" dia x 3.25" Long
	1	222000	<i>Sheet Clamp Cylinder 8" Assembly</i>	
13	12	1003804	*Bolts, Cylinder Gland (LOCTITED)	SHCS 0.625-18 x 1.0" Long
14	1	1004852	*Rod Wiper	AN Wiper SH959-53
15	1	1004542	*Rod Seal	250-06.000-375B Lubrithane Polyseal
16	1	222004	Front Plate Seal, Cylinder Gland	
17	1	222014	*Rod Wear Band	Wear Guide 06250-0750-125
18	1		*Head Seal O-Ring and Backup	568-367 CMPD F-7001 and 80-367 Contoured Backup
19	1	222007	8" Sheet Cylinder Rod	
20	1	1006105	*Piston Seal	PS1850-128 Bronze PTFE w/ Energizer
21	1		*Piston Wear Band	Wear Guide 08000-0750-125
22	1	1001409	8" Hydraulic Cylinder Barrel	
23	2	130057	90 Elbow Fitting, #6 JIC to #6 ORB	FITT2L-06M06R
24	1	222016	P.O. Check Valve	CKEB-XCN
25	8	124205	*Washers, Cylinder Mounting	HCLW 1.25"
26	8	124204	*Bolts, Cylinder Mounting	SHCS 1.25-12x4.0" Long
27	1	221001	*Grease-zerk	Straight 1/8" NPT

*Included in Seal or Bolt Kit

Model 150
Sheet/Dunce Clamp

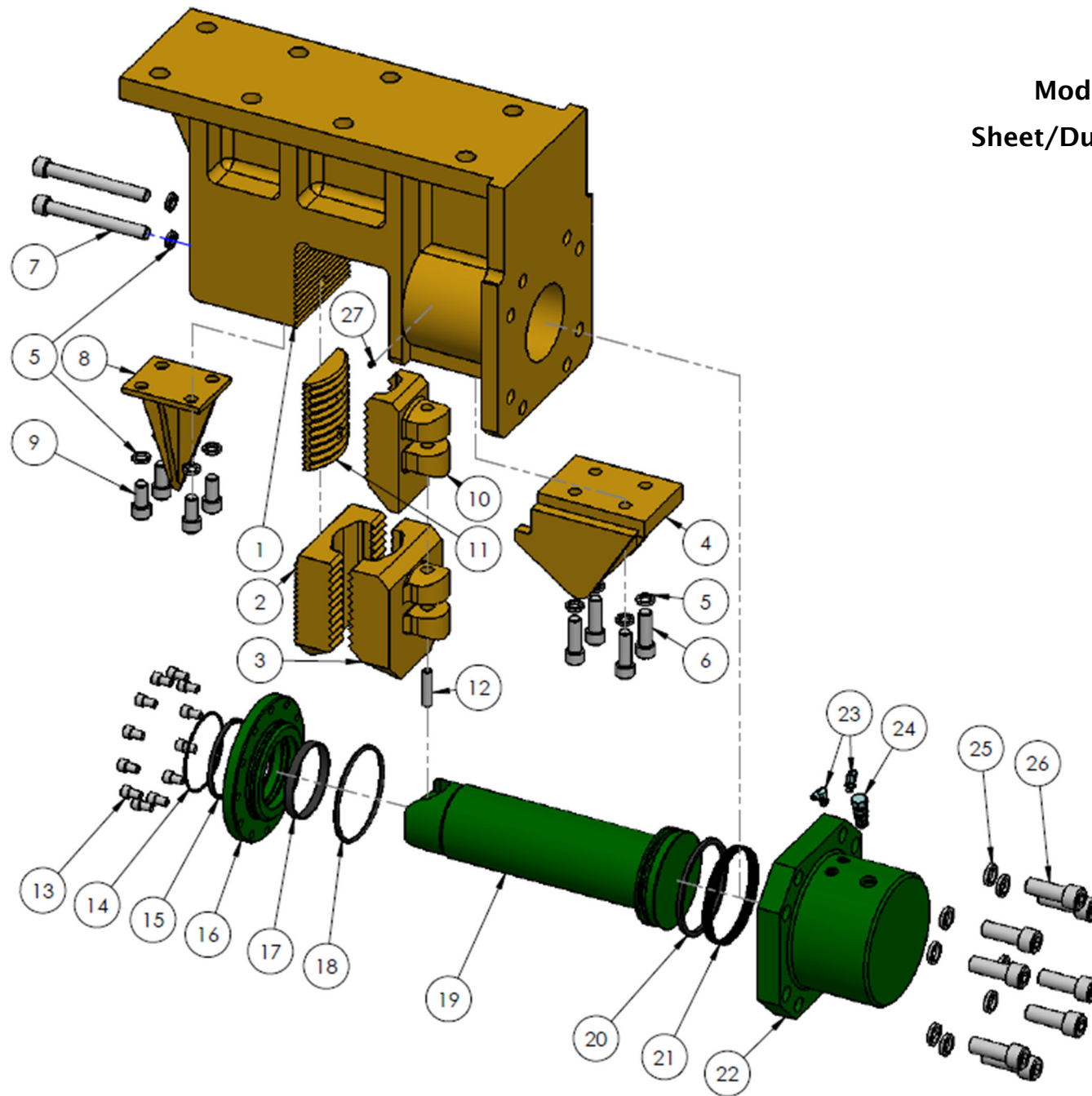

Model 200 Sheet Clamp

Item	Quantity	APE Number	Description	Manufacturer Information
1	1	232001	Model 200 Sheet Clamp Body w/ Rod Bushing	
2	1	221011	Fixed Jaw, Double Sheet	
3	1	221005	Moveable Jaw, Double Sheet	
4	1	221017	Sheet Pile Guide	
5	6	124207	*Washers, General	HCLW 1.0"
6	4	1003018	*Bolts, Pile Guide	SHCS 1.0-8x3.0" Long
7	2	120206	*Bolts, Fixed Jaw	SHCS 1.0-8x9.0" Long
	1	222000	Sheet Clamp Cylinder 8" Assembly	
8	12	1003804	*Bolts, Cylinder Gland (LOCTITED)	SHCS 0.625-18x1.0" Long
9	1	1004852	*Rod Wiper	AN Wiper SH959-53
10	1	1004542	*Rod Seal	250-06.000-375B Lubrithane Polyseal
11	1	222004	Front Plate Seal, Cylinder Gland	
12	1	222014	*Rod Wear Band	Wear Guide 06250-0750-125
13	1		*Head Seal O-Ring and Backup	568-367 O-Ring CMPD F-7001 and 80-367 Contoured Backup
14	1	232007	8" Sheet Cylinder Rod 200	
15	1		*Piston Seal	PS1850-128 Bronze PTFE w/ Energizer
16	1		*Piston Wear Band	Wear Guide 08000-0750-125
17	1	1001409	8" Hydraulic Cylinder Barrel	
18	2	130057	90 Elbow Fitting, #6 JIC to #6 ORB	FITT2L-06M06R
19	1	222016	P.O. Check Valve	CKEB-XCN
20	8	120205	*Washers, Cylinder Mounting	HCLW 1.25"
21	8	124204	*Bolts, Cylinder Mounting	SHCS 1.25-12x4.0" Long
22	1	221001	*Grease-zerk	Straight 1/8 NPT
23	1	221002	Jaw Pin	Spiral Pin 0.75" dia x 3.25" Long

*Included in Seal or Bolt Kit

Model 200
Sheet Clamp

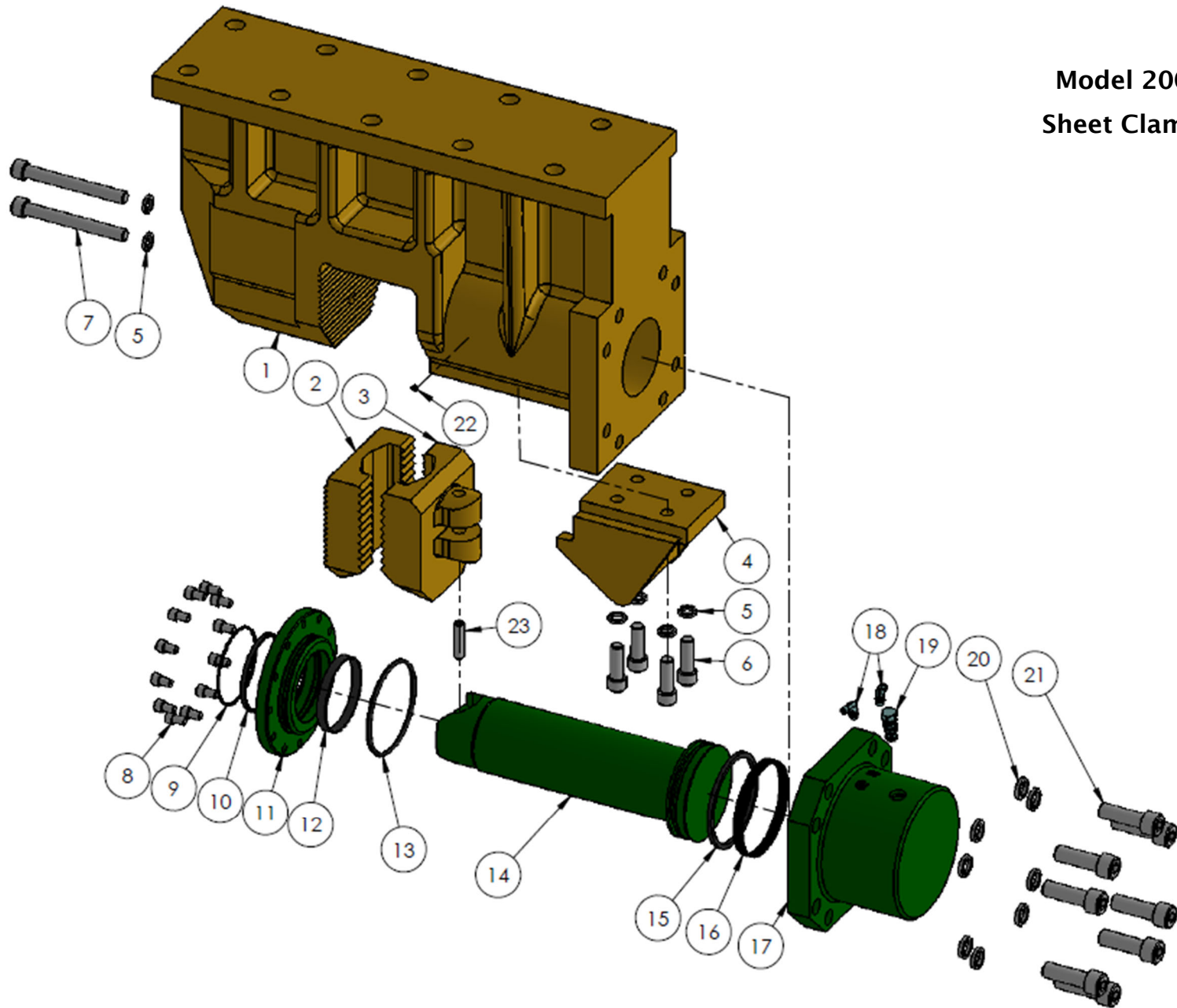

Model 300 Sheet Clamp

Item	Quantity	APE Number	Description	Manufacturer Information
1	1	1009879	APE 300 Clamp Body Mach	
2	1	221011	Fixed Jaw, Double Sheet	
3	1	221005	Movable Jaw, Double Sheet	
4	1	221002	Jaw Pin	Spiral Pin 0.75" x 3.0" Long
5	3	120929	Rod Wear Ring	7.0 ID x 7.25 OD x 2.0" Verco Cool blue ultra precision wear ring
6	1	100983	Pile Guide	
7	18	100209	Washers, Common	HCLW 1.0"
8	4	100213	Bolts, Pile Guide	SHCS 1.0-8x2.5" Long
9	2	1003081	Bolts, Fixed Jaw	SHCS 1.0-8x4.25" Long
	1	1009877	300 Cylinder Assembly	
10	1	120917	196 Cylinder Bucket	
11	1	1009878	SC 300 Piston Rod	
12	1	120919	Rod End Cap - 196	
13	2	120551	*Piston Bearing	612-1000-050
14	1	120915	*Piston Seal and Expander	PR-10000-60B w/-447 Expander
15	1	120549	*Gland Seal	448 GT Ring
16	1	120555	*Rod Bearing	0.5x7.00x.12
17	1	120553	*Rod Seal	TR-056
18	1	120921	*Rod Wiper	SH959-57
19	12	100575	Bolts, Cylinder Gland (LOCTITED)	SHCS 0.625-11x1.25" Long
20	2	130057	90 Elbow Fitting, #6 JIC to #6 ORB	FITT2L-06M06R
21	1	120629	Check Valve	Sun CKCD-XEN
22	1	122014	#6 MORB Plug	6408-H06-O
	1	1003082	**Soc Set Cone PT	1/2-13x1.0"
23	12	100212	Bolts, Cylinder Mounting	SHCS 1.0-8x4.0" Long
24	1	221001	Grease-zerk	Straight 1/8" NPT

*Included in Seal Kit

**Used in place of MORB plug in older models

Model 300
Sheet Clamp

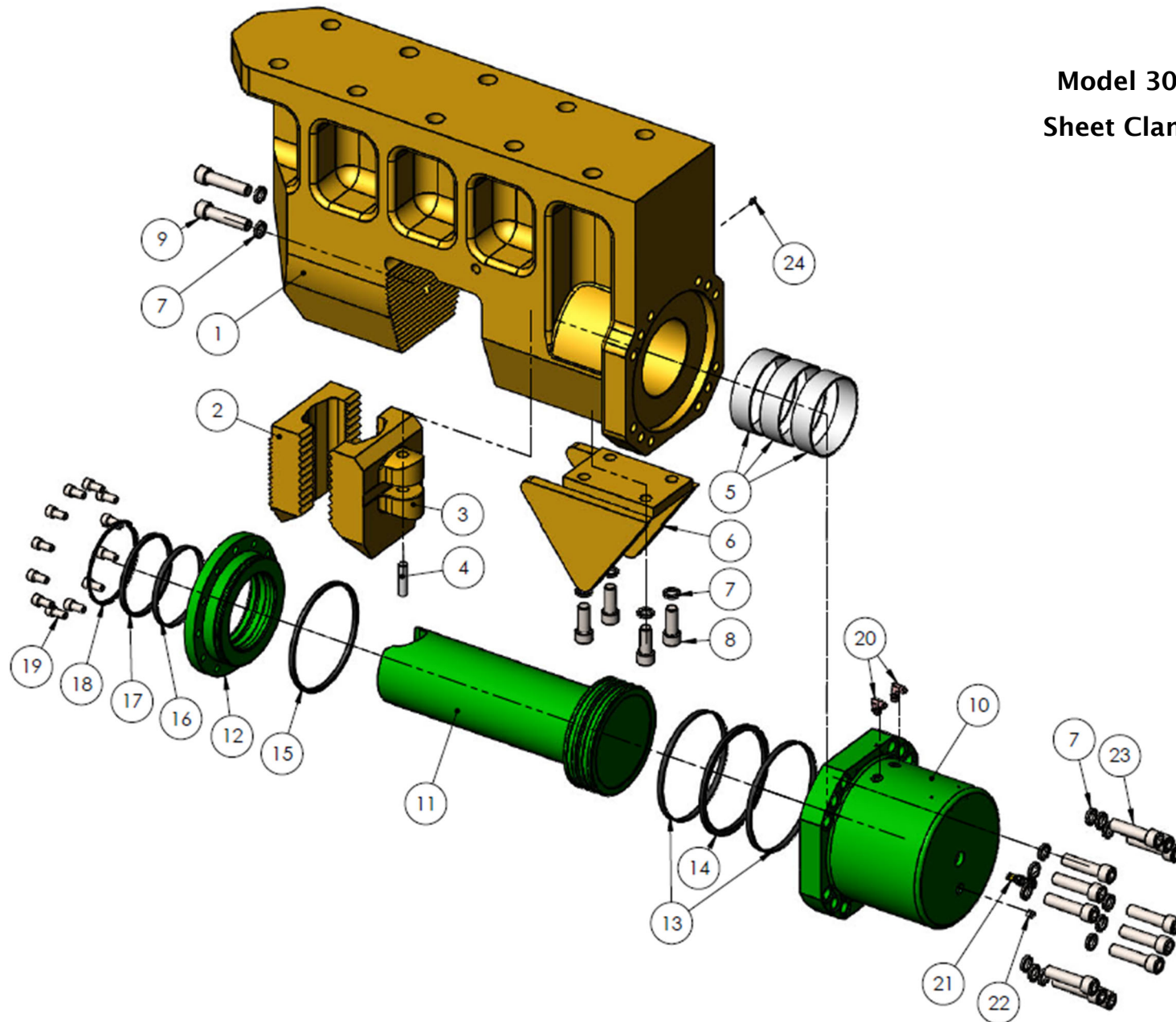

Model 400 Sheet Clamp

Item	Quantity	APE Number	Description	Manufacturer Part Number
1	1	1001112	Model 400T Sheet Clamp Body w/ Sleeve	
2	1	1001115	Fixed Jaw, 400 Clamp	
3	1	1001116	Moveable Jaw, 400 Clamp	
4	1	1002304	400 Sheet Clamp Pile Guide	
5	36	124207	*Washers, Common	HCLW 1.0"
6	4	1003018	*Bolts, Pile Guide	SHCS 1.0-8x3.0" Long
7	2	160844	*Bolts, Fixed Jaw	SHCS 1.0-8x11.0" Long
8	1	1001111	Plastic Sleeve	
	1		Model 400 Clamp Cylinder Assembly	
9	15		*Bolts, Cylinder Gland (LOCTITED)	SHCS 0.625-18 x 1.75" Long
10	1	1002261	*Rod Wiper	D010000 10" Rod Wiper Slotted
11	1	1002260	Rod Seal	P-50010000-750-4615 Deep Polypack, Polyurethane
12	1	1001114	400 Clamp - Gland	
13	1		Rod Wear Band	PDTF 10" OD x 1" Wide x 1/8 Thk Bronze Filled Teflon Wear Ring
14	1		*Head Seal O-Ring and Backup	Parker 2-458 and 8-458 Backup
15	1	1001113	400 Clamp - Piston / Rod	
16	1		Piston Seal	P-50014000-750-4615 Deep Polypack, Polyurethane
17	1		Piston Wear Band	PDTC 15" OD x 1" Wide x 1/8 Thk Bronze Filled Teflon Wear Ring
18	1	1001117	400 Clamp - Cylinder Bucket	
19	2	130057	90 Elbow Fitting, #6 JIC to #6 ORB	FITT2L-06M06R
20	1	222016	P.O. Check Valve	CKEB-XCN
21	1	1001160	Thermal Relief Valve	Hydra Force TF04-B20-0-PC-60
22	1	110935	Plug, #4 ORB	FITT2P-04R
23	30	300015	*Bolts, Cylinder Mounting	SHCS 1.0-8x5.0" Long
24	4	221001	*Grease-zerk	Straight 1/8" NPT
25	1	221002	*Jaw Pin	Spiral Pin 0.75" dia x 3.25" Long

*Included in Seal or Bolt Kit

Model 400
Sheet Clamp

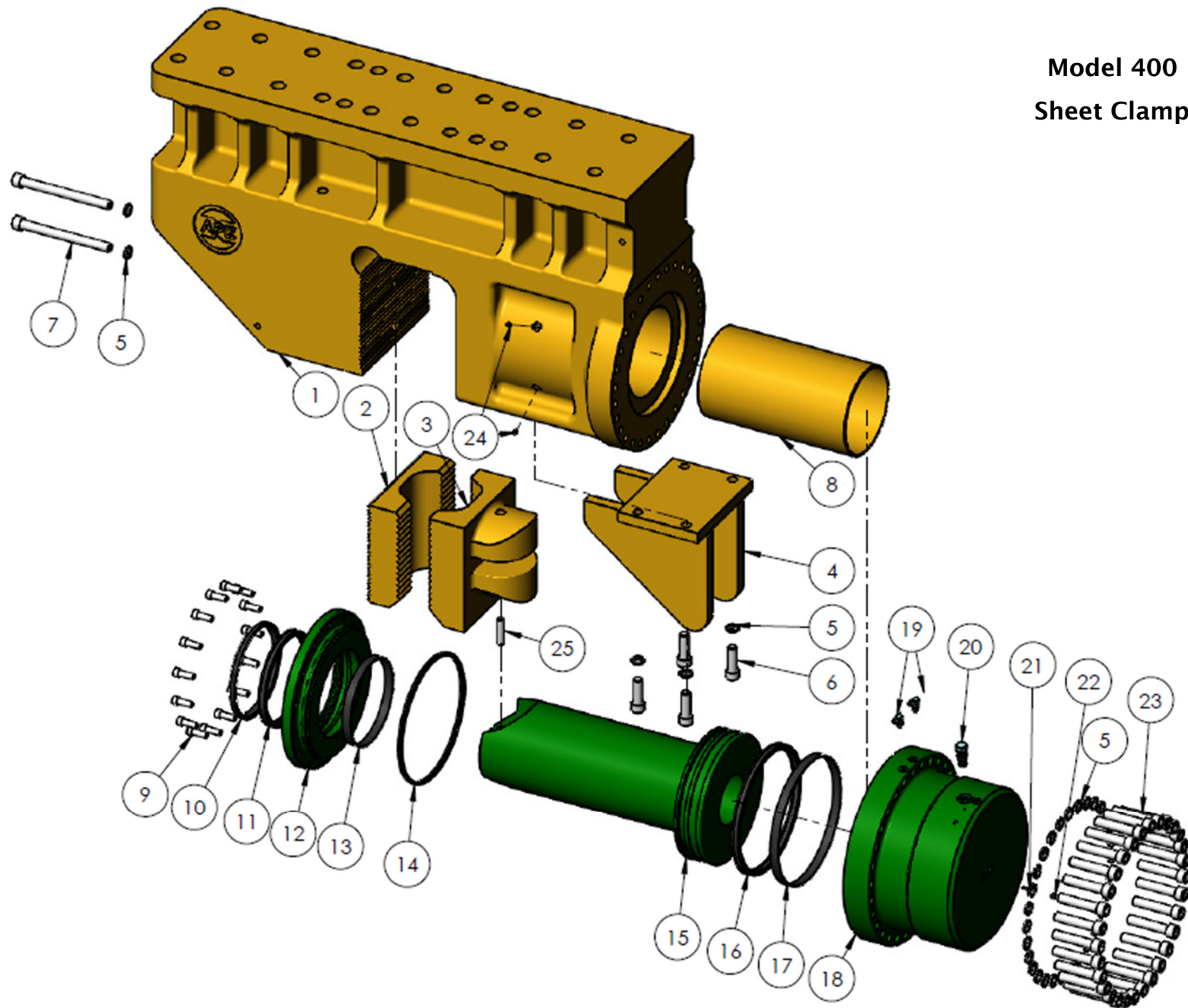

Model 126 J&M Sheet Clamp

Item	Quantity	APE Number	Description	Manufacturer Information
1	1	810493	126 Clamp Body	
2	1	110419	Fixed Jaw, DS	
	1	110515	(or) Fixed Jaw, Universal	
	1	110541	(or) Fixed Jaw, H-Beam	
3	1	810499	Moveable Jaw, DS	
	1	810495	(or) Moveable Jaw, 126b Universal	
	1	810497	(or) Moveable Jaw, 126b H-Beam	
4	1	120929	Wear Ring	7 ID x 7.25 OD x 4.010 Verco Cool Blue Ultra Precision Wear Ring
5	1	100983	Pile Guide	
6	16	100209	Washers, Common	HCLW 1.0"
7	4	100213	Bolts, Pile Guide and Cylinder/Piston	SHCS 1.0-8x2.5" Long
8	1	130449	Jaw Pin	Spiral Pin 0.75"x3.0" Long
	1		126 Cylinder Assembly	
9	1	120401	*Gland Seal	2-269 O-Ring 90 Durometer
10	1	120553	*Rod Seal	TR-056 Rod T-Seal Buna-N
11	1	120555	*Rod Bearing	.5Wx7.00IDx.12
12	1	120567	126B Rod End Cap	
13	2	120283	*Head / Piston Seal	TP-064 Piston T-Seal Buna-N
14	1	120931	126B 1pc Piston & Rod	
	1	120575	126 Cylinder Rod**	
	1	120849	*Piston & Cylinder Rod Seal**	2-261 O-Ring 90 Durometer
	1	120569	126 Piston**	
	3	100213	Bolts, Cylinder/Piston	SHCS 1.0-8x2.5" Long
15	2	120285	*Piston Bearing	912-8000-500
16	1	810491	126 Clamp Bucket	
17	2	130057	90 Elbow Fitting, #6 JIC to #6 ORB	FITT2L-06M06R
18	1	120629	P.O. Check Valve	CKCD-XEN
19	12	100212	Bolts, Cylinder Mounting and Fixed Jaw	SHCS 1.0-8x4.0" Long
20	1	221001	Grease-zerk	Straight 1/8" NPT
21	1	1003082	Soc Set Cone PT	1/2-13x1.0"

*Included in Seal or Bolt Kit

**Replaces item 14 in some models

Model 126 J&M
Sheet Clamp

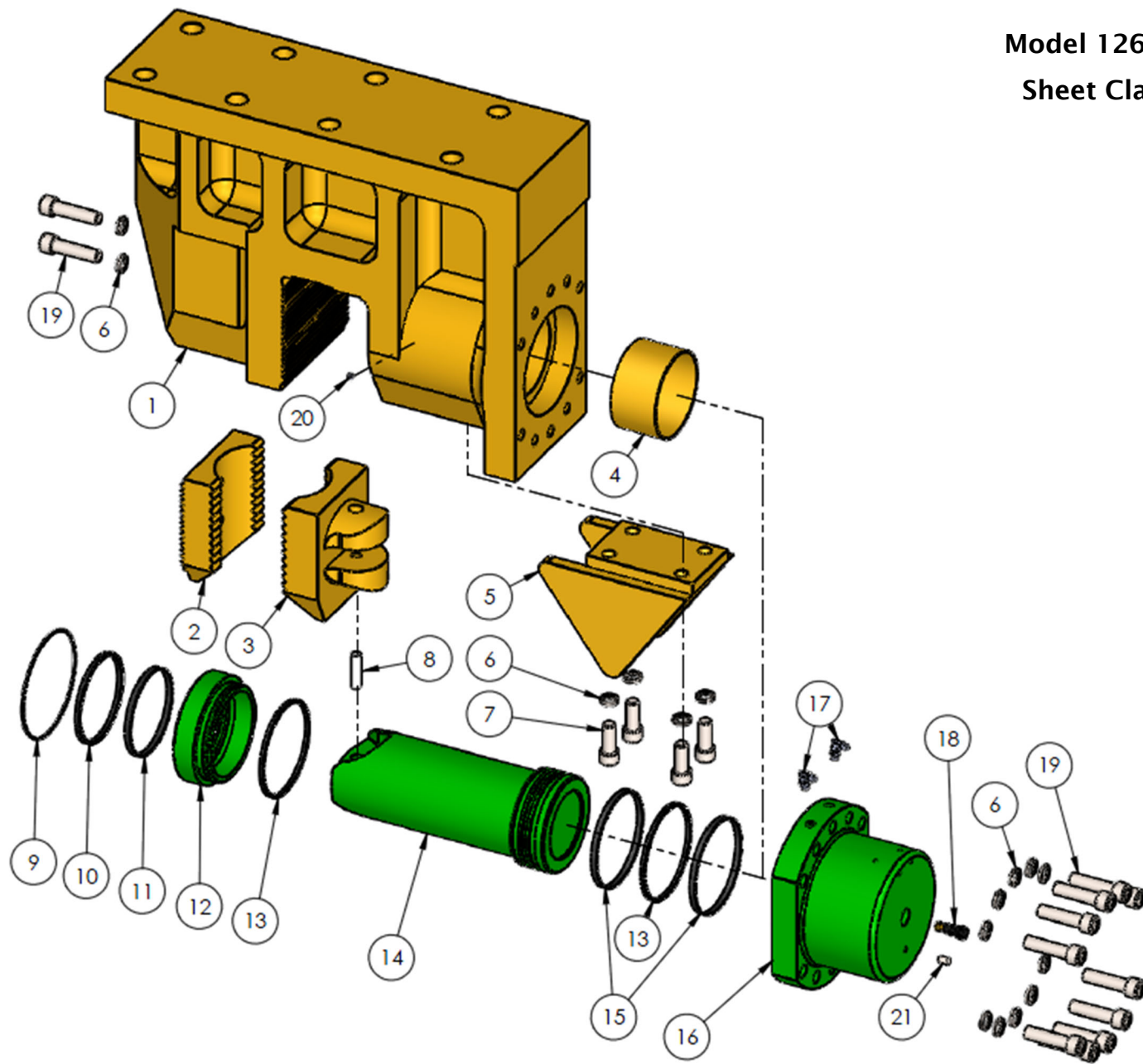

Model 196 J&M Sheet Clamp

Item	Quantity	APE Number	Description	Manufacturer Information
1	1	810947	196 Clamp Casting Assembly	
2	1	810463	Fixed Jaw, 196 Clamp	
3	1	810461	Moveable Jaw, 196 Clamp	
4	1	130449	Jaw Pin	Spiral Pin 0.75" x 3.0" Long
5	2	120929	Rod Wear Ring	7.0 ID x 7.25 OD x 2.0" Verco Cool blue ultra precision wear ring
6	1	100983	Pile Guide	
7	18	100209	Washers, Common	HCLW 1.0"
8	4	100213	Bolts, Pile Guide	SHCS 1.0-8x2.5" Long
9	2	1003021	Bolts, Fixed Jaw	SHCS 1.0-8x4.5" Long
	1		196 Cylinder Assembly	
10	12	100575	Bolts, Cylinder Gland (LOCTITED)	SHCS 0.625-11x1.25" Long
11	1	120921	Rod Wiper	SH959-57
12	1	120553	*Rod Seal	TR-056 Rod T-Seal Buna-N
13	1	120555	*Rod Bearing	612-0725-050
14	1	120919	Rod End Cap - 196	
15	2	120915	Head Seal	TP-069 T-Seal Buna-N
16	1	120913	196 1pc Piston & Rod	
	1	120535	<i>196 Cylinder Rod**</i>	
	1	120347	<i>*Piston/Cylinder Rod Seal**</i>	2-261 O-Ring 90 Duro
	1	120537	<i>196 Piston**</i>	
	3	1001628	<i>Bolts, Piston/Cylinder Rod**</i>	SHCS 1.5-6x3.0" Long
17	2	120551	*Piston Bearing	612-1000-050
18	1		*Piston Seal	PS1850-160 Bronze PT
19	1	120917	196 Cylinder Bucket	
20	2	130057	90 Elbow Fitting, #6 JIC to #6 ORB	FITT2L-06M06R
21	1	120629	Check Valve	Sun CKCD-XEN
22	12	100212	Bolts, Cylinder Mounting	SHCS 1.0-8x4.0" Long
23	1	221001	Grease-zerk	Straight 1/8" NPT
24	1	1003082	Soc Set Cone PT	1/2-13x1.0"

*Included in Seal kit
 **Replaces item 16 in some models

Model 196 J&M
Sheet Clamp

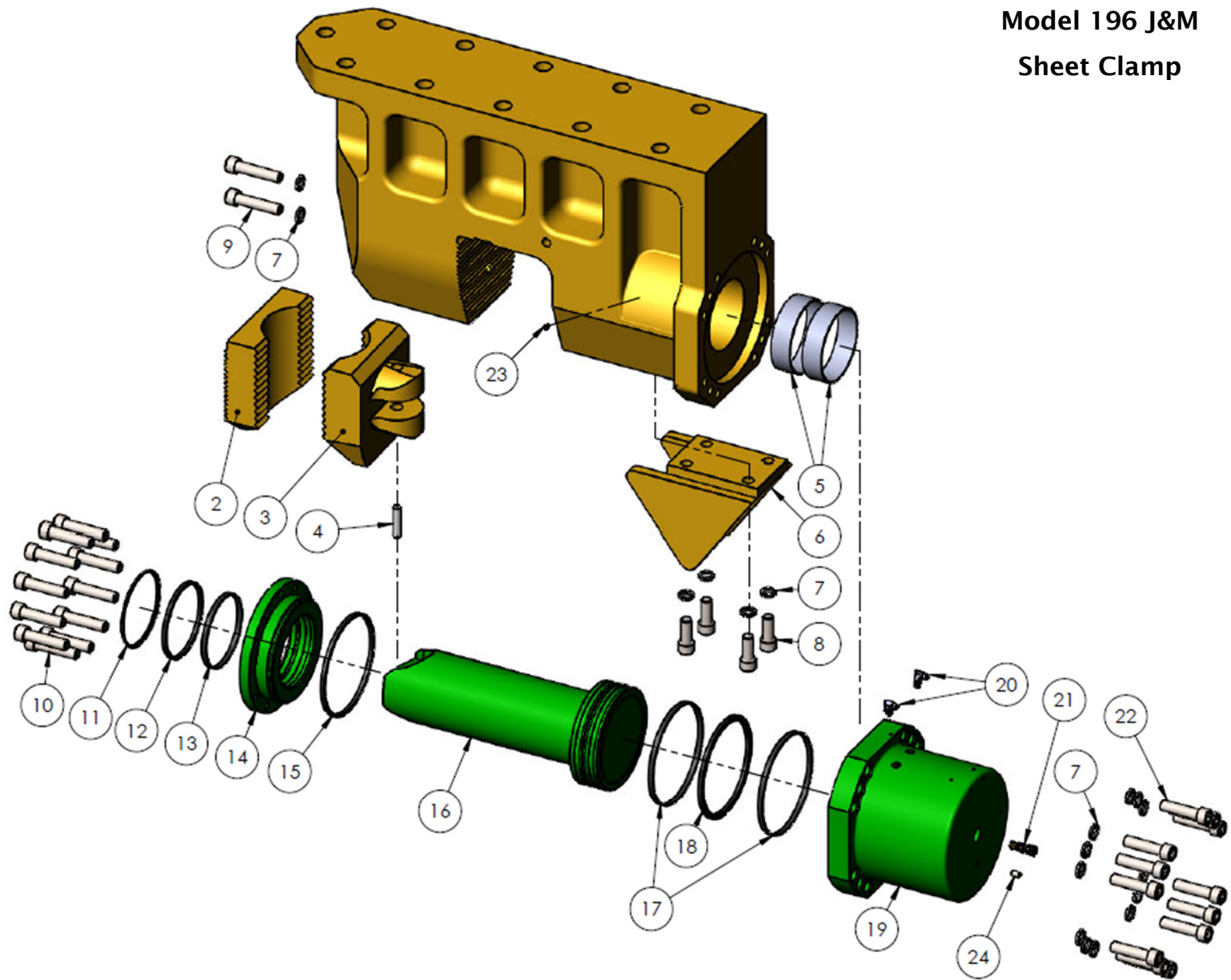

Model 80 Caisson Clamp

Item	Quantity	APE Number	Description	Manufacturer Information
1	1	810061	80B Clamp Housing	
2	1	120107	Fixed Jaw, Caisson	
3	2	100119	*Bolts, Wedge Guard	SHCS 0.5-13x1.25" Long
4	4	100121	*Washers, Wedge Guard and Chain Anchor	HCLW 0.5"
5	1	120119	Wedge Guard	
6	2	400157	*Bolts, Fixed Jaw	SHCS 0.625-11x2.75" Long
7	2	124115	Washers, Fixed Jaw	HCLW 0.625"
8	1	120751	Chain Anchor	
9	2	100513	*Bolts, Chain Anchor	SHCS 0.5-13x1.5" Long
	2	810109	80b Screw Assembly (*Quantities below given per subassembly)	
10	1**	120201	Threaded Rod	1.25-4x13.75" Long ACME
11	2**	120199	Wedge Nut	1.25-4 Hex Nut ACME
12	1**	120521	Spring Pin	0.375x2.0" Long
13	4	120111	*Washers, Screw Assembly	1.25 H.S. Flat Washer
14	2	120101	Wedge, Male Half, Brass	
15	2	120103	Wedge, Female Half, Steel	
16	5	221001	*Grease-zerk	Straight 1/8" NPT
	1		Model 80 Clamp Cylinder Assembly	
17	1	120345	*Rod Wiper	AN Wiper SH959-41
18	1	120625	*Rod Seal	Parker BR 3120 4500
19	1	120627	Rod Bearing	W0-4750-500
20	1	120100	Plate Seal	Parker 2-263 90 durometer
21	1	120623	Rod End Cap	
22	1	120347	*Gland Seal O-Ring and Backup	Parker 2-261 90 durometer and 8-261 backup
23	1	120631	Cylinder Rod	
24	1	120281	*Rod and Cap Seal O-Ring	Parker 2-140 90 durometer
25	1	120313	Piston	
26	2	120355	*Piston Bearings	W2-7000-500
27	1	120357	*Piston Seal	TP-060 Piston T-Seal Buna-N
28	1	120621	80B Clamp Cylinder Bucket	
29	2	130057	90 Elbow Fitting, #6 JIC to #6 ORB	FITT2L-06M06R
30	1	120629	P.O. Check Valve	CKCD-XEN
31	8	100209	*Washers, Cylinder Mounting	HCLW 1.0"
32	8	100212	*Bolts, Clamp Mounting	SHCS 1.0-8x4.0" Long

33	1	*Set Screw	1/2-13x1.0" Long HSSS
----	---	------------	-----------------------

*Included in Seal or Bolt kit

**Model 80
Caisson Clamp**

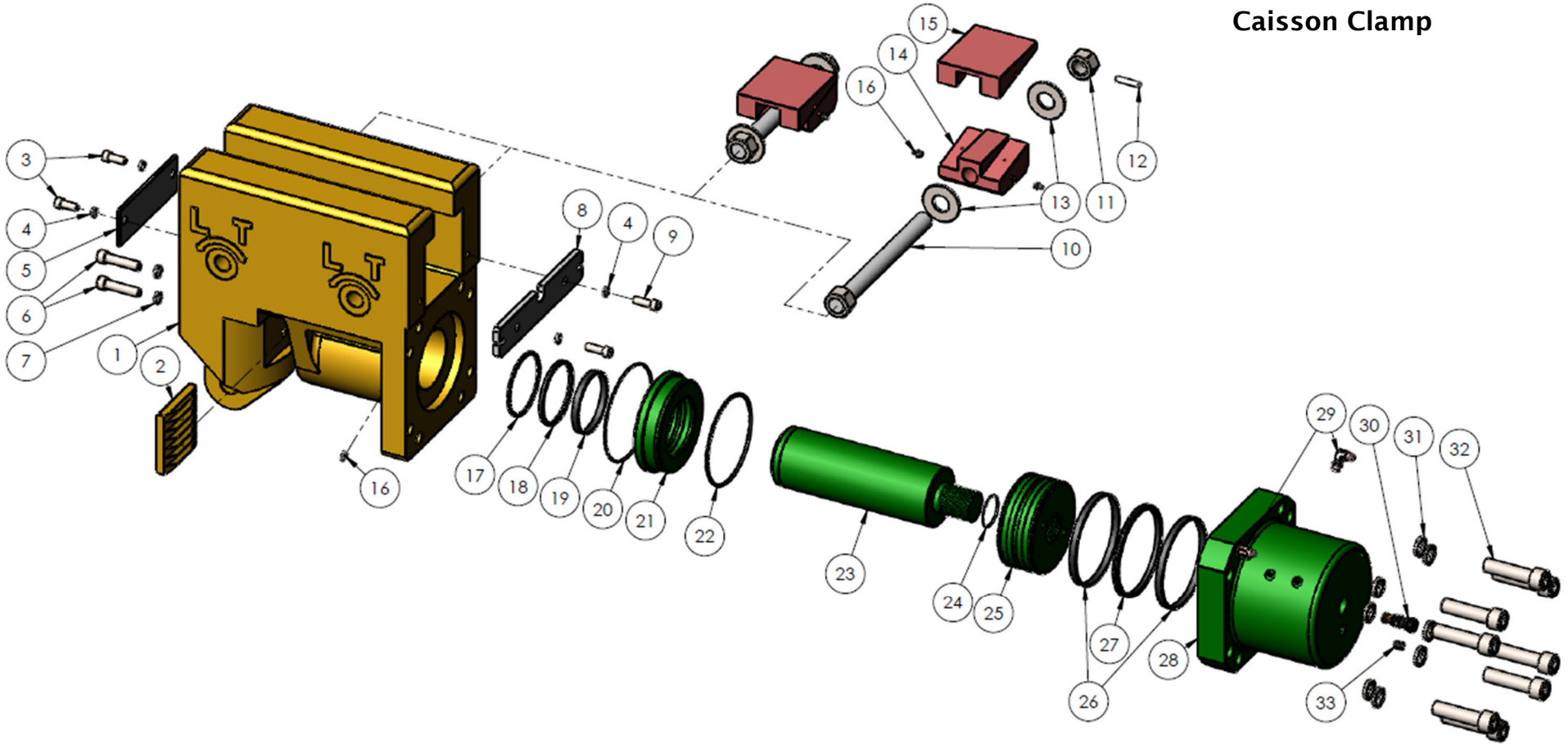

Model 100 Caisson Clamp

Item	Quantity	APE Number	Description	Manufacturer Information
1	1	250101	Model 100 Caisson Clamp Body	
2	1	250202	Fixed Jaw, Caisson 1.25" Thick	
	1	250202N	(or) Fixed Jaw, Caisson 0.75" Thick	
	2	124211A	APE Caisson Screw Assembly (*Quantities below given per subassembly)	
3	1**		Threaded Rod	1.25-5x14" Long ACME rod
4	2**	120111	1.25" H S Flat Washer	Fastenal 33124, 1/8" thick, plain F436
5	2**	124212	Wedge Nut	1.25-5 ACME Hex Nut
6	2	250102	Wedges, Male Half, Bronze	
7	2	250105	Wedges, Female Half, Steel	
8	5	221001	*Grease-zerk	Straight 1/8" NPT
	1	250001	Caisson Clamp Cylinder Assembly	
9	12	1003804	Bolts, Cylinder Gland (LOCTITED)	SHCS 0.625-18x1.0" Long
10	1		*Rod Wiper	AN Wiper SH959-53
11	1		*Rod Seal	250-06.000-375B Lubrithane Polyseal
12	1	222004	Cylinder Gland	
13	1		*Rod Wear Band	Wear Guide 06250-0750-125
14	1		*Head Seal O-Ring and Backup	568-367 O-Ring CMPD F-7001 and 80-367 Contoured Backup
15	1	250003	8" Caisson Piston and Rod	
16	1		*Piston Seal	PS1850-128 Bronze PTFE w/ Energizer
17	1		*Piston Wear Band	Wear Guide 08000-0750-125
18	1	1001409	8" Hydraulic Cylinder Bucket	
19	2	130057	90 Elbow Fitting, #6 JIC to #6 ORB	FITT2L-06M06R
20	1	222016	P.O. Check Valve	CKEB-XCN
21	1	122014	#6 MORB Plug	6408-H06-O
22	8	124205	*Washers, Cylinder Mounting	HCLW 1.25"
23	8	124204	*Bolts, Cylinder Mounting	SHCS 1.25-12x4.0" Long
24	2	110308	*Bolts, Fixed Jaw	SHCS 0.625-11x4.0" Long
25	2	124115	*Washers, Fixed Jaw	HCLW 0.625"

*Included in Seal or Bolt kit

Model 100
Caisson Clamp

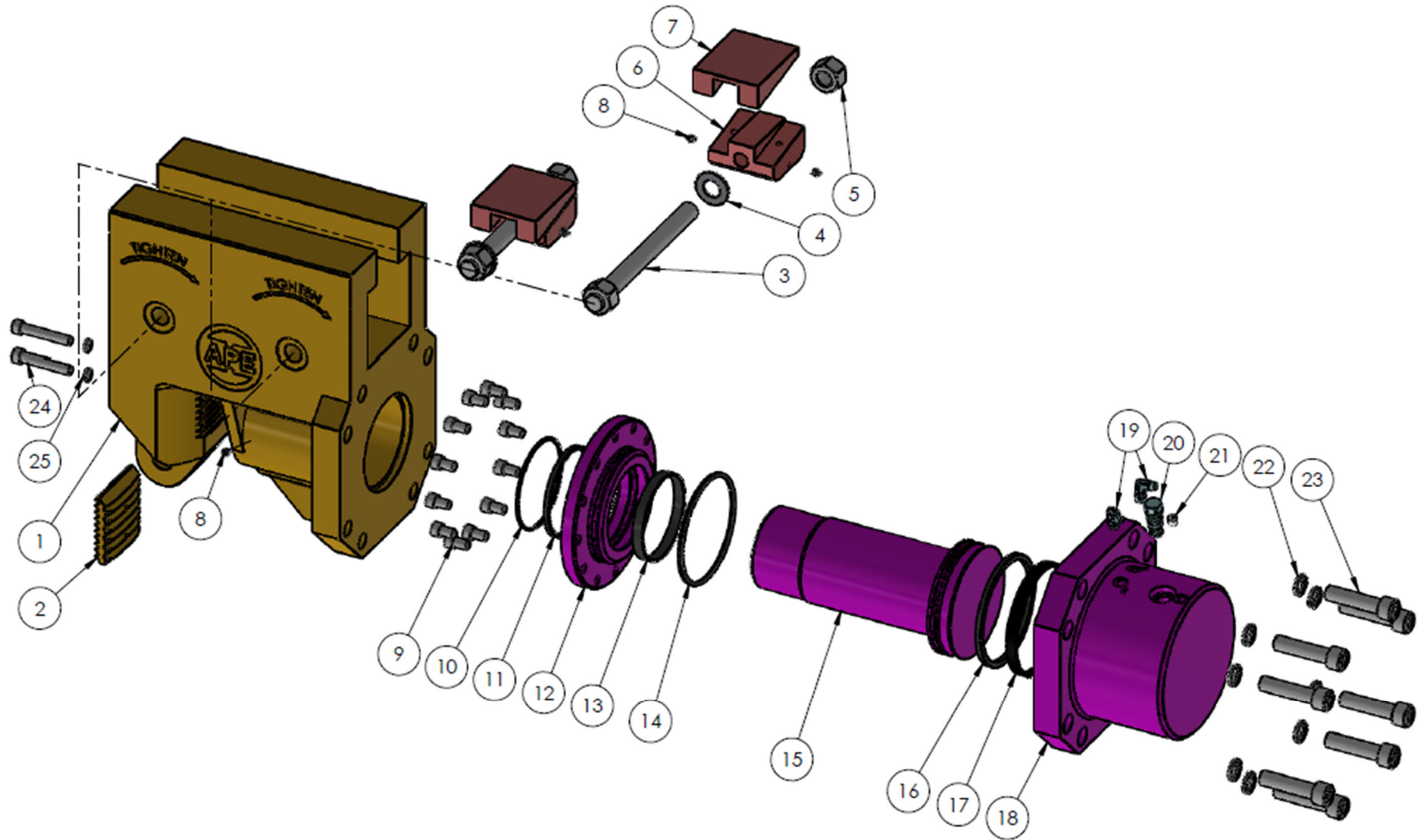

Model 200 Caisson Clamp

Item	Quantity	APE Number	Description	Manufacturer Information
1	1	260101	Caisson Clamp 200 Body w/ Rod Bushing	
2	1	250202	Fixed Jaw, Caisson 1.25" Thick	
	1	250202N	(or) Fixed Jaw, Caisson 0.75" Thick	
	1	250202H	(or) Fixed Jaw, Caisson 1.5" Thick	
	3	124211A	APE Caisson Screw Assembly (*Quantities below given per subassembly)	
3	1**		Threaded Rod	1.25-5x14" Long ACME rod
4	2**	120111	1.25" H S Flat Washer	Fastenal 33124, 1/8" thick, plain F436
5	2**	124212	Wedge Nut	1.25-5 ACME Hex Nut
6	3	250102	Wedge, Male Half, Bronze	
7	3	250105	Wedge, Female Half, Steel	
8	7	221001	*Grease-zerk	Straight 1/8" NPT
	1	250001	Caisson Clamp Cylinder Assembly	
9	12	1003804	Bolts, Cylinder Gland (LOCTITED)	SHCS 0.625-18x1.0" Long
10	1		*Rod Wiper	AN Wiper SH959-53
11	1		*Rod Seal	250-06.000-375B Lubrithane Polyseal
12	1	222004	Cylinder Gland	
13	1		*Rod Wear Band	Wear Guide 06250-0750-125
14	1		*Head Seal O-Ring and Backup	568-367 O-Ring CMPD F-7001 and 80-367 Contoured Backup
15	1	250003	8" Caisson Piston and Rod	
16	1		*Piston Seal	PS1850-128 Bronze PTFE w/ Energizer
17	1		*Piston Wear Band	Wear Guide 08000-0750-125
18	1	1001409	8" Hydraulic Cylinder Bucket	
19	2	130057	90 Elbow Fitting, #6 JIC to #6 ORB	FITT2L-06M06R
20	1	222016	P.O. Check Valve	CKEB-XCN
21	1	122014	#6 MORB Plug	6408-H06-O
22	8	124205	*Washers, Cylinder Mounting	HCLW 1.25"
23	8	124204	*Bolts, Cylinder Mounting	SHCS 1.25-12x4.0"
24	2	124214	*Bolts, Fixed Jaw	SHCS 0.625-11x4.25"
25	2	124115	*Washers, Fixed Jaw	HCLW 0.625"

*Included in Seal or Bolt kit

Model 200
Caisson Clamp

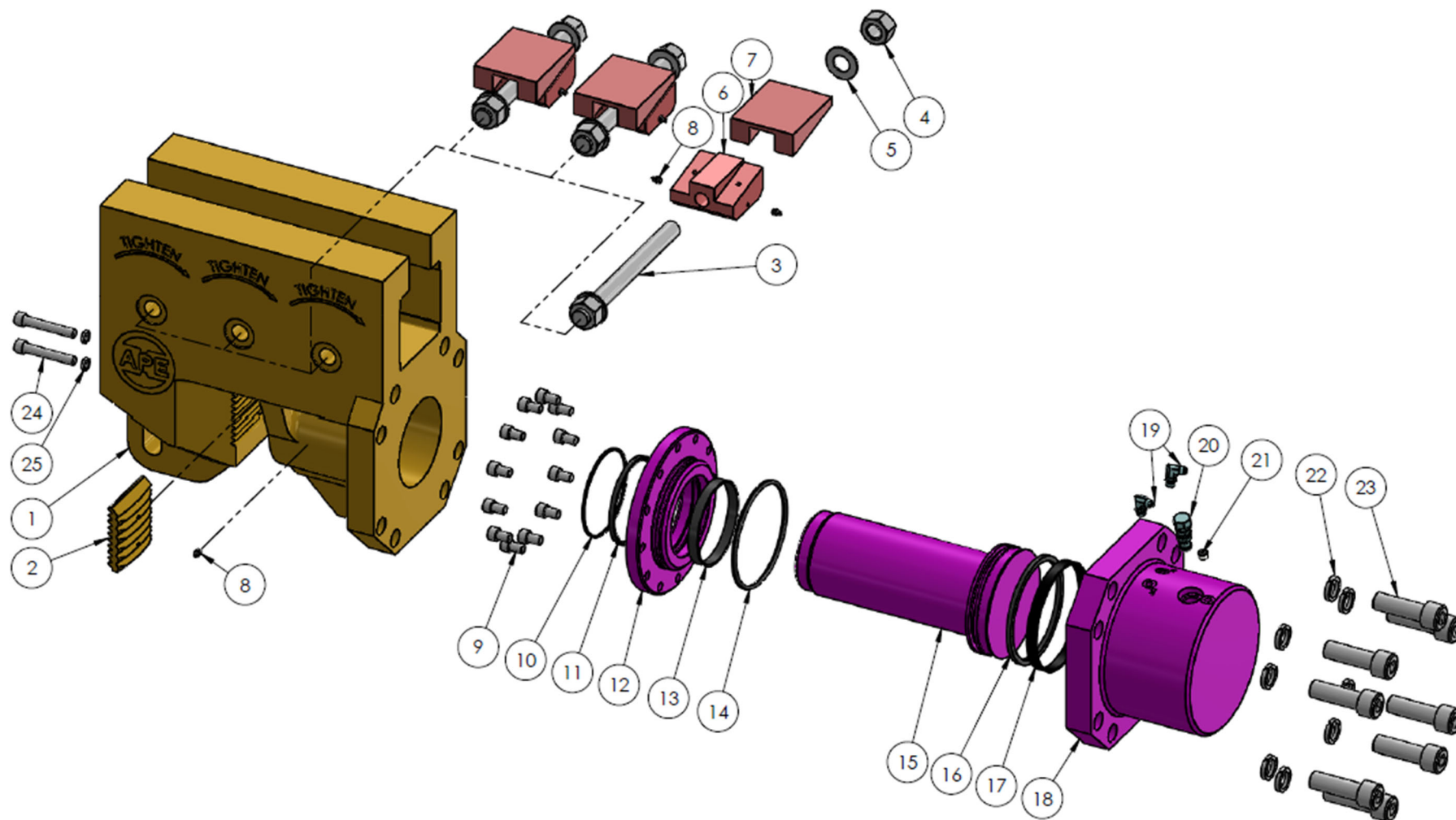

Model 20 Wood Clamp

Item	Quantity	APE Number	Description	Manufacturer Information
1	1	1002218	Model 20 Wood Clamp Body	
	1	1002125	20" Swing Arm Assembly	
2	1	1002219	20" WC Swing Arm	
3	1	1002124	20" WC Moveable Jaw Pivot	
4	1	1002123	20" WC Moveable Jaw Shaft	
5	2		Swing Arm Cover	3.0" dia x 3/16" Thick
		1002126	Wood Clamp Cylinder Assembly	
6	2	130057	90 Elbow Fitting, #6 JIC to #6 ORB	FITT2L-06M06R
7	1	1002127	Cylinder Barrel Assembly	
		1002131	Cylinder Rod Assembly	
8	2		*Rod Wear Rings	8000-76E
9	1		*Gland Seal O-Ring and Backup	568-363 O-Ring N70 and 80-363 Contoured Backup
10	1	1002130	Cylinder Gland	
11	1		*Rod Seal	250-04.500-375B-PO Lubrithane Polyseal
12	1		*Rod Wiper	AN Wiper AN-41-SH Urethane
13	12		Bolts, Cylinder Gland	SHCS 0.625-18x2.0" Long
14	4	400401	Bolts, Piston	SHCS 1.0-8x2.0" Long
15	2		*Piston Wear Rings	Wear Ring 612-700-100
16	1		*Piston Seal	TFE-R-7000 Teflon
17	1	1002129	Cylinder Piston	
18	1		*Rod and Cap Seal w/ Double Backups	568-246 O-Ring N70, (x2) 80-246 Contoured Backups
19	1	1002128	Cylinder Rod and Clevis Assembly	
20	2	1002133	Spring Bushing	Connex 3.5" OD x 3.0" ID x 2.25" Long
21	2	1002134	Spring Bushing	Connex 3.5" OD x 3.0" ID x 1.25" Long
22	1	1002136	Swing Arm Shaft	
23	2	1002137	Cylinder Pin	
24	4	1002132	Spring Bushing	Connex 3.0" OD x 2.5" ID x 1.5" Long
25	2	1002135	Spring Bushing	Connex 3.0" OD x 2.5" ID x 2.5" Long
26	2	1002138	Cylinder Pin Keeper	
			Jaws for Concrete	
27	1	1002212	Moveable Jaw - Concrete 20"	
28	1	1002213	Fixed Jaw - Concrete 20"	
			Jaws for Wood	
29	2	1002140	Ape Wood Jaw, Right Hand 23"	
30	2	1002139	Ape Wood Jaw, Left Hand 23"	
31	2	1002211	Spacer - Wood Jaws	
32	5	221001	Grease-zerk	Straight 1/8" NPT

33	2		Cotter Pin	Stainless Steel 0.25"x4.0" or longer
34	12	124202	Washers, Jaws	HCLW 1.5"
35	6	120819	Bolts, Moveable Jaw	SHCS 1.5-6x4.0" Long
36	6	100193	Bolts, Fixed Jaw	SHCS 1.5-6x6.5" Long

*Included in Seal or Bolt Kit

Model 20 Wood Clamp

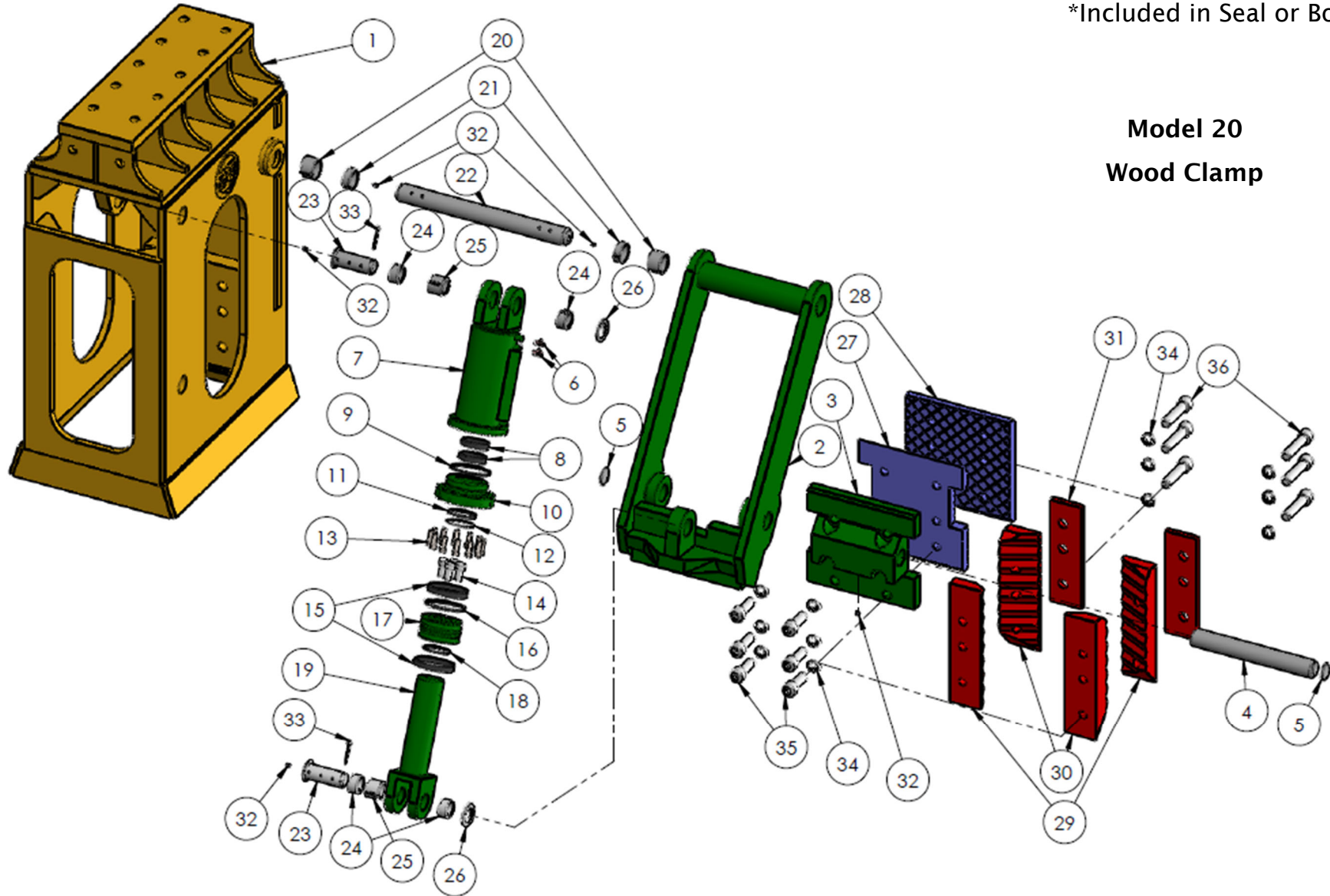

Model 25 Wood Clamp

Item	Quantity	APE Number	Description	Manufacturer Information
1	1	1002224	Model 25 Wood Clamp Frame	
	1	1002231	25" Swing Arm Assembly	
2	1	1002226	25" WC Swing Arm	
3	1	1002227	25" WC Moveable Jaw Pivot	
4	1	1002228	25" WC Moveable Jaw Shaft	
5	2	1002230	Swing Arm Cover	3.0" dia x 0.25" Thick
		1002126	Wood Clamp Cylinder Assembly	
6	2	130057	90 Elbow Fitting #6 JIC to #6 ORB	FITT2L-06M06R
7	1	1002127	Cylinder Barrel Assembly	
		1002131	Cylinder Rod Assembly	
8	2		*Rod Wear Rings	8000-76E
9	1		*Gland Seal O-Ring and Backup	568-363 O-Ring N70 and 80-363 Contoured Backup
10	1	1002130	Cylinder Gland	
11	1		*Rod Seal	250-04.500-375B-PO Lubrithane Polyseal
12	1		*Rod Wiper	AN Wiper AN-41-SH Urethane
13	12		Bolts, Cylinder Gland	SHCS 0.625-18x2.0" Long
14	4	400401	Bolts, Piston	SHCS 1.0-8x2.0" Long
15	2		*Piston Wear Rings	Wear Ring 612-700-100
16	1		*Piston Seal	TFE-R-7000 Teflon
17	1	1002129	Cylinder Piston	
18	1		*Rod and Cap Seal w/ Double Backups	568-246 O-Ring N70, (x2) 80-246 Contoured Backups
19	1	1002128	Cylinder Rod and Clevis Assembly	
20	2	1002233	Spring Bushing	Connex 4.0" OD x 3.5" ID x 3.0" Long
21	2	1002232	Spring Bushing	Connex 4.0" OD x 3.5" ID x 2.25" Long
22	1	1002229	Swing Arm Shaft	
23	2	1002137	Cylinder Pin	
24	4	1002235	Spring Bushing	Connex 3.0" OD x 2.5" ID x 1.5" Long
25	2	1002234	Spring Bushing	Connex 3.0" OD x 2.5" ID x 2.5" Long
26	2	1002138	Cylinder Pin Keeper	
			Jaws for Concrete	
27	1	1002236	Moveable Jaw, Concrete 25"	
28	1	1002237	Fixed Jaw, Concrete 25"	
			Jaws for Wood	
29	2	1002140	Ape Wood Jaw, Right Hand 23"	
30	2	1002139	Ape Wood Jaw, Left Hand 23"	
31	2	1002211	Spacer - Wood Jaws	
32	5	221001	Grease-zerk	Straight 1/8" NPT

33	2		Cotter Pin	Stainless Steel 0.25"x4.0" or longer
34	12	124202	Washers, Common	HCLW 1.5"
35	6		Bolts, Fixed Jaw	SHCS 1.5-6x3.25" Long
36	6	120819	Bolts, Moveable Jaw	SHCS 1.5-6x4.0" Long

*Included in Seal or Bolt Kit

Model 25 Wood Clamp

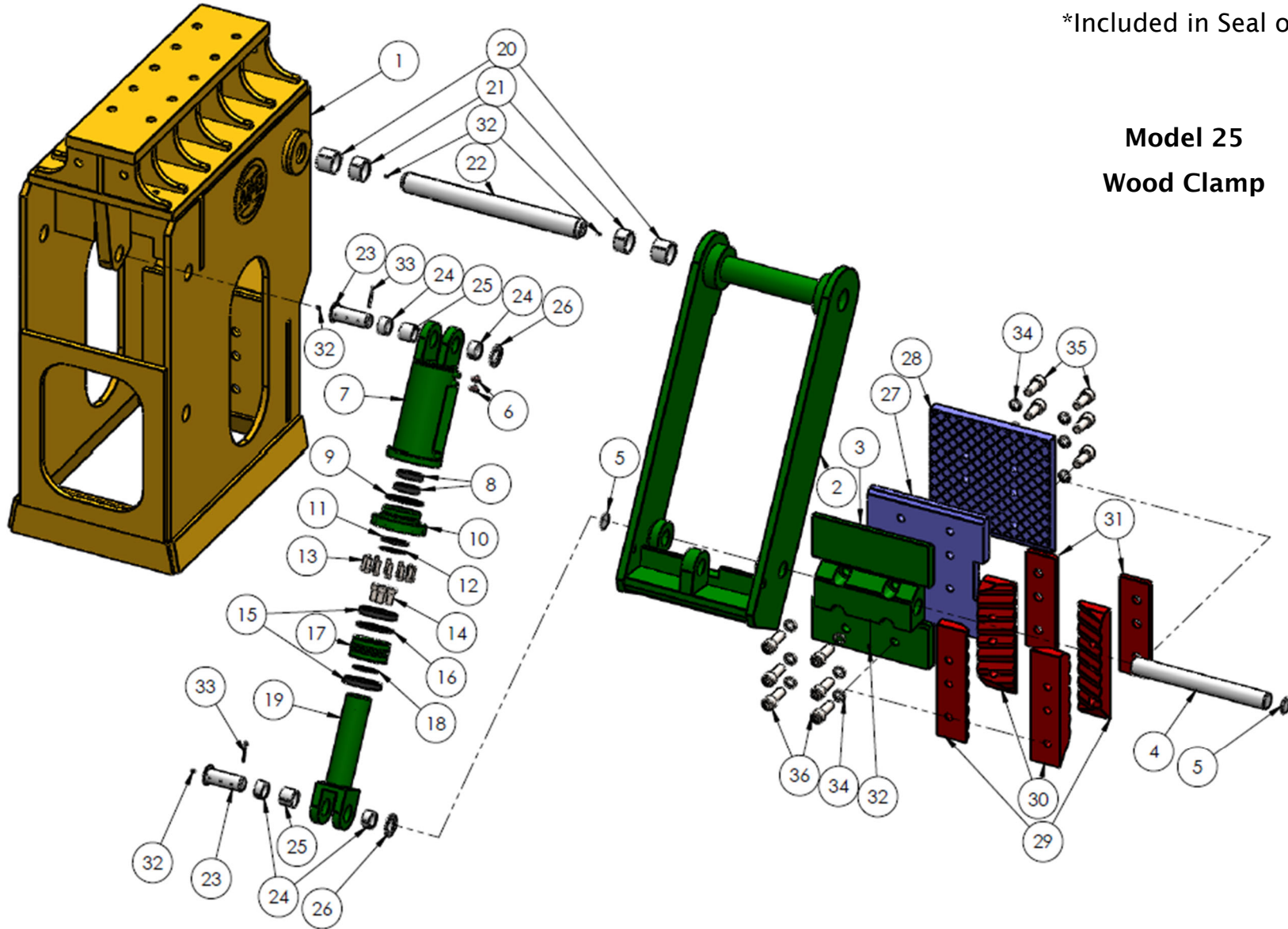

Model 32 Wood Clamp

Item	Quantity	APE Number	Description	Manufacturer Information
1	1		Model 32 Wood Clamp Frame	
	1		32" Swing Arm Assembly	
2	1		32" WC Swing Arm	
3	1		32" WC Moveable Jaw Pivot	
4	1		32" WC Moveable Jaw Shaft	
5	2		Swing Arm Cover	3.0" dia x 3/16" Thick
			Wood Clamp Cylinder Assembly	
6	2	130057	90 Elbow Fitting, #6 JIC to #6 ORB	FITT2L-06M06R
7	1		Cylinder Barrel Assembly	
			Cylinder Rod Assembly	
8	2		*Rod Wear Rings	8000-76E
9	1		*Gland Seal O-Ring and Backup	2-367N70 and 8-363 Backup
10	1	1002130	Cylinder Gland	
11	1		*Rod Seal	250-04.500-375B-PO Lubrithane Polyseal
12	1		*Rod Wiper	AN Wiper AN-41-SH Urethane
13	12		Bolts, Cylinder Gland	SHCS 0.625-18x2.0" Long
14	4	400401	Bolts, Piston	SHCS 1.0-8x2.0" Long
15	2		*Piston Wear Rings	Wear Ring 612-700-100
16	1		*Piston Seal	TFE-R-7000 Teflon
17	1	1002129	Cylinder Piston	
18	1		*Rod and Cap Seal w/ Double Backups	568-246 O-Ring N70, (x2) 80-246 Contoured Backups
19	1	1002128	Cylinder Rod and Clevis	
20	2		Spring Bushing	Connex 3.5" ID x 4.0" OD x 2.75" Long
21	2		Spring Bushing	Connex 3.5" ID x 4.0" OD x 3.5" Long
22	1		Swing Arm Shaft	
23	2		32" WC Cylinder Pin	
24	2	1002234	Spring Bushing	Connex 3.5" ID x 4.0" OD x 2.5" Long
25	2	1002138	Cylinder Pin Keeper	
			Jaws for Concrete	
26	1	909015	Moveable Jaw, Concrete 32"	
27	1	909013	Fixed Jaw, Concrete 32"	
28	18	124202	Washers, Common	HCLW 1.5"
29	2		Cotter Pin	Stainless Steel 0.25"x4.0" or longer
30	5	221001	Grease-zerk	Straight 1/8" NPT
			Jaws for Wood	
31	2	1002140	Ape Wood Jaw, Right Hand 23"	
32	2	1002139	Ape Wood Jaw, Left Hand 23"	

33	2	1002211	Spacer - Wood Jaws	
34	12		Bolts, Fixed Jaw	SHCS 1.5-6x3.25" Long
35	6	120819	Bolts, Moveable Jaw	SHCS 1.5-6x4.0" Long

*Included in Seal or Bolt Kit

Model 32 Wood Clamp

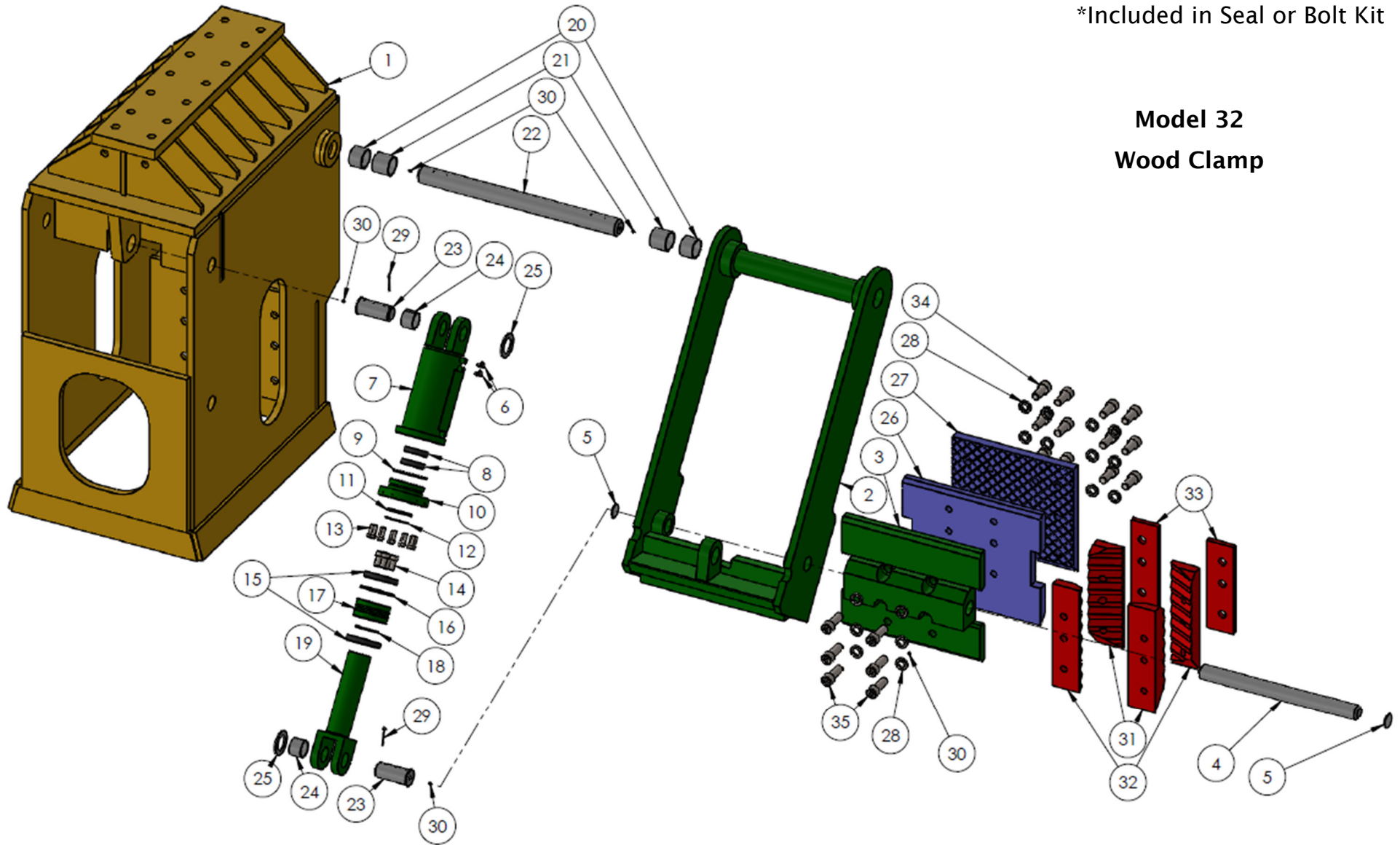

Hybrid 20 Clamp

Item	Quantity	APE Number	Description	Manufacturer Information
1	1	1007195	Model 20 Hybrid Clamp Body	
2	1	1007193	Guard Guide	
3	1	1007197	Inside Moveable Jaw	
4	1	1007199	Outside Moveable Jaw	
5	2	1007201	Adaptor Pipe	
6	2	1007200	Cross Head	
7	2		Bolts, Arm Mount	HHBolt 1.25-12x11.0x2.0
8	2	120859	Georgia-Yates Hydraulic Cylinder	Yates H6A-N4.0x12x1.75T4S11
		1000432	*Seal Kit and Replacement Gland	GHC-HH-PRG-017
9	25	1003063	Washers, General	HCLW 1.0
10	12	140731	Bolts, Moveable Jaw	SHCS 1.0-8x9.5x2.5
11	8	1003020	Bolts, Cylinder Mounting	SHCS 1.0-8x4.0
12	8	1003019	Bolts, Guard Guide Attachment Rear	SHCS 1.0-8x3.25x3.25
13	5		Bolts, Guard Guide Attachment Front	SHCS 1.0-8x3.5x2.5
14	8		Nuts, Guard Guide Attachment	Stover Nut 1.0-8
15	4	221001	Grease-zerk	Straight 1/8" NPT
	1	120861	Combined Clamp Manifold	
16	1	120933	Clamp Manifold C102	
17	1	120877	Check Valve	CKCB-XEN
18	2	100053	Straight Fitting, #6 JIC to #6 ORB	FITT2S-06M06R
19	2	130057	90 Elbow Fitting, #6 JIC to #6 ORB	FITT2L-06M06R
20	2		90 Elbow Fitting, #6 JIC to #6 ORB, Double Long	FITT2L-06M06R000-00X
21	4	130645	Straight Fitting, #6 JIC to #8 ORB	FITT2S-06M08R

*Included in Seal Kit

Model 20
Hybrid Clamp

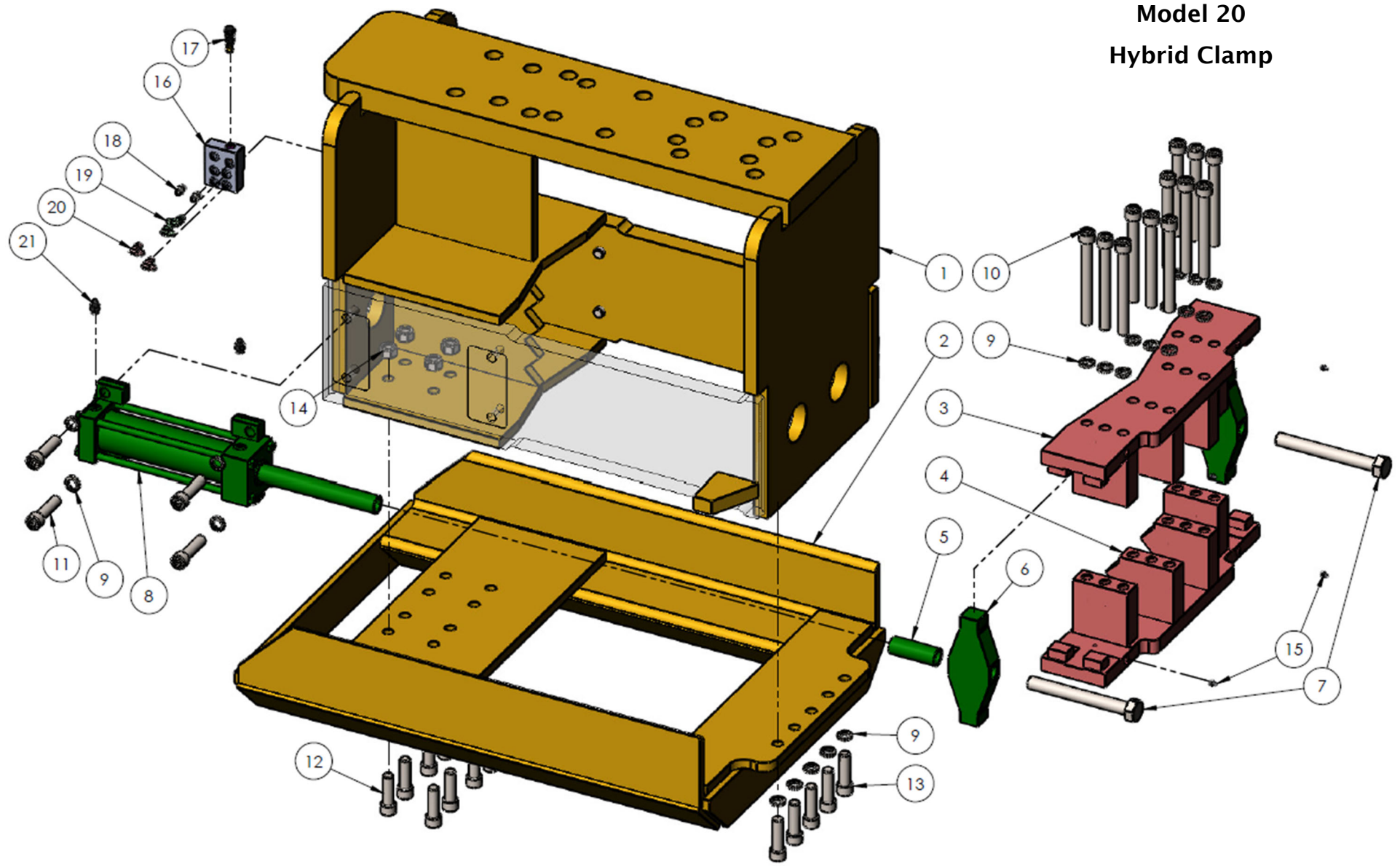

C102 Clamp

Item	Quantity	APE Number	Description	Manufacturer Information
1	1	810879	Clamp Body Assembly	
2	1	120865	Guard Guide	
3	1	120867	Inside Moveable Jaw	
4	1	120869	Outside Moveable Jaw	
5	2	120871	Cross Head	
6	2		Bolts, Arm Mount	SHCS 1.25-12x6.0
7	12	140731	Bolts, Moveable Jaw	SHCS 1-8x9.5
8	2	120859	Georgia-Yates Hydraulic Cylinder	Yates H6A-N4.0x12x1.75T4S11
		1000432	*Seal Kit and Replacement Gland	GHC-HH-PRG-017
9	33	1003063	Lockwashers, Common	HCLW 1"
10	2	1003065	Lockwashers, Arm Mount	HCLW 1.25"
11	8	400051	Hex Nut, Guard Guide Mount	HHNUT 1.0-8
12	13	140145	Bolts, Guard Guide Mount Rear	SHCS 1.0-8x3.5
13	8	1003018	Bolts, Guard Guide Mount Front	SHCS 1.0-8x3.0
14	4	221001	Grease-zerk	Straight 1/8" NPT
	1	120861	Combined Clamp Manifold	
15	1	120933	Clamp Manifold C102	
16	1	120877	Check Valve	CKCB-XEN
17	2	100053	Straight Fitting, #6 JIC to #6 ORB	FITT2S-06M06R
18	2	130057	90 Elbow Fitting, #6 JIC to #6 ORB	FITT2L-06M06R
19	2		90 Elbow Fitting, #6 JIC to #6 ORB, Double Long	FITT2L-06M06R000-00X
20	4	130645	Straight Fitting, #6 JIC to #8 ORB	FITT2S-06M08R

*Included in Seal Kit

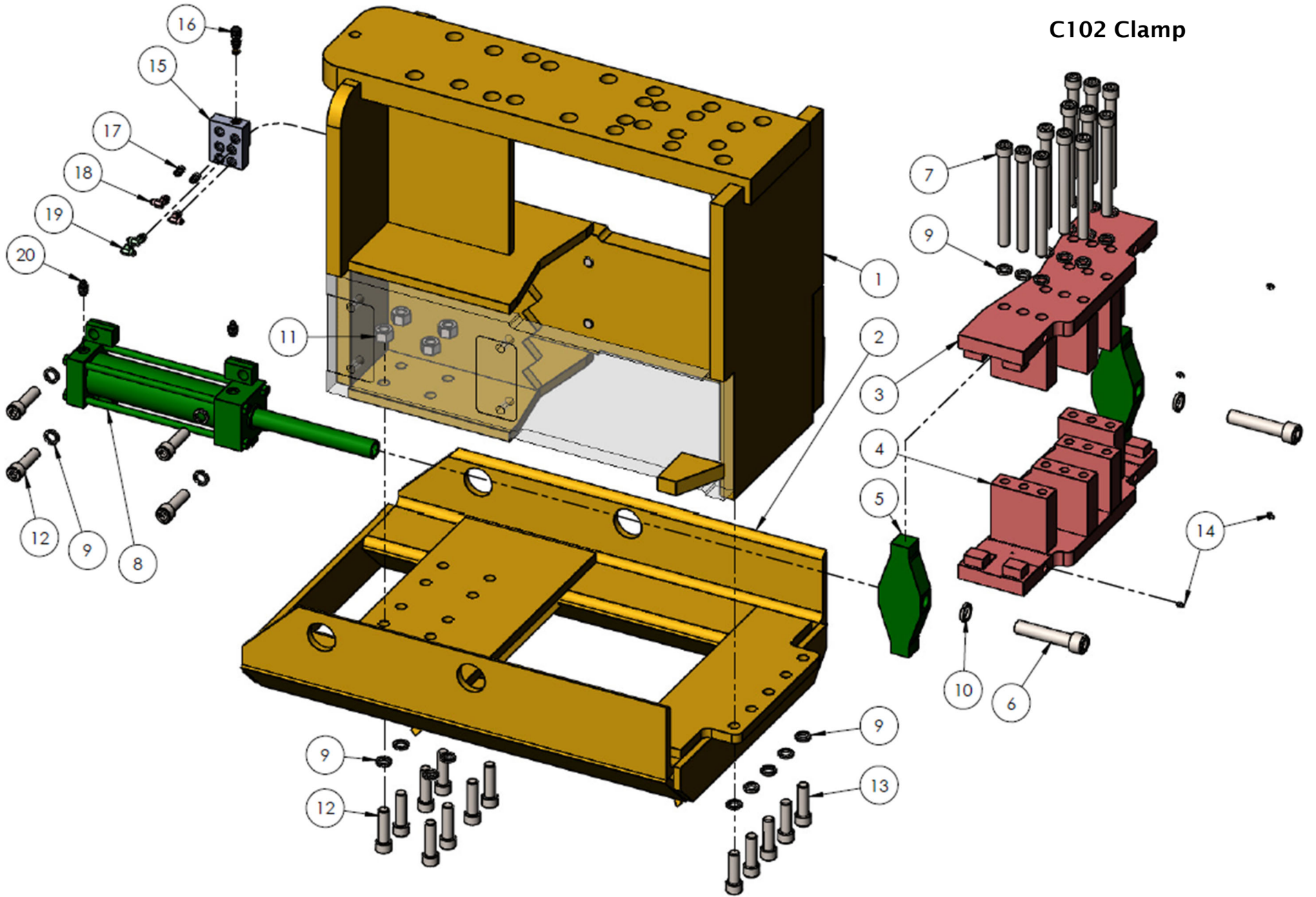

C102 Clamp

Caisson Beam Adaptor

Item	Quantity	APE Number	Description	Manufacturer Information
1	1	1004820	Caisson Beam Adaptor Body	
2	4	124211A	Caisson Wedge Screw Welded Assembly	
3	4	250102	Wedge, Male Half, Bronze	
4	8	221001	Grease-zerk	Straight 1/8" NPT
5	4	250105	Wedge, Female Half, Steel	
6	4	120111	1.25" H S Flat Washer	Fastenal 33124, 1/8" thick, plain F436
7	4	124212	Wedge Screw End Nut	1.25"-5 ACME Hex Nut

Caisson Beam Adaptor

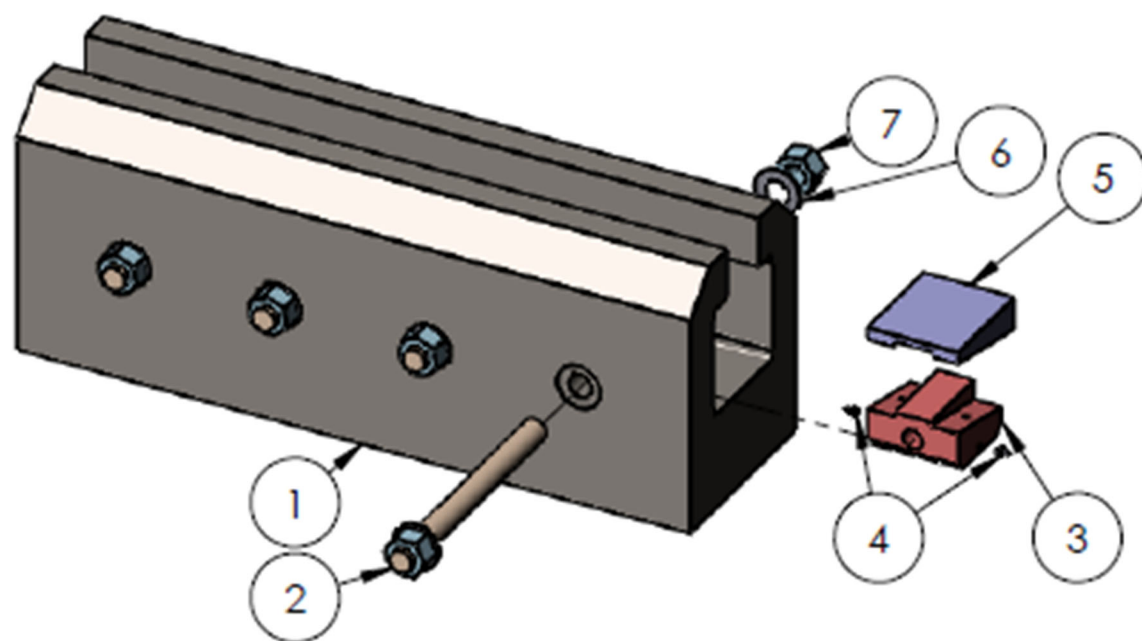

Seal Kits

New Style Model 3/6		Hybrid 20 Clamp	
Kit #205210A	Quantity	Kit #1000432	Quantity
2-236 O-Ring	1	GHC-HH-PRG-017 Combined Gland/Seals	1
8-236 O-Ring Backup	1	Model 80 Caisson Clamp	
2500-2000-375B	1	Kit #810227	Quantity
Custom Bronze Filled Ring with PTFE	1	AN Wiper SH959-41	1
W125-03375-0250	1	Parker BR 3120 4500 Rod Seal	1
Model 20 Sheet Clamp		TP060 Piston T-Seal Buna-N	1
Kit #208010	Quantity	W2-7000-500 Piston Bearing	2
568-238 O-Ring CMPD N-7002	1	2-261 O-Ring 90 Duro	1
568-248 O-Ring CMPD N-7002	2	8-261 Backup	1
568-345 O-Ring CMPD N-7002	2	2-140 O-Ring 90 Duro	1
80-248 Contoured Backup	1	Model 400 Sheet	
80-345 Contoured Backup	1	Kit #1002262	Quantity
Wear Ring 612-500-100	2	2-458 Gland O-Ring	1
Wear Ring 8000-68B	1	8-458 Gland O-Ring Backup	1
DT-4000 Wiper U-1003	1	P-50014000-750 Deep Polypak	1
PS1850-80 Bronze PTFE w/ Energizer	1	15" OD x 1.0" Wide x 1/8" Thick Bronze Filled Teflon Wear Ring	1
Model 50, 150, 200 Sheet AND Model 100, 200 Caisson		10" OD x 1.0" Wide x 1/8" Thick Bronze Filled Teflon Wear Ring	1
Kit #1003614	Quantity	D010000 10" Rod Wiper Slotted	1
AN Wiper SH959-53	1	P-50010000-750 Deep Polypak	1
250-06.000-375B Lubrithane Polyseal	1	Model 126 Sheet Clamp	
Wear Guide 06250-050-125	1	Kit #810515	Quantity
568-367 O-Ring CMPD F-7001	1	2-269 O-Ring 90 Duro	1
80-367 Contoured Backup	1	0.5Wx7.00IDx0.12	1
PS1850-128 Bronze PTFE w/ Energizer	1	TR-056 Rod T-Seal Buna-N	1
Wear Guide 08000-0750-125	1	TP-064 Piston T-Seal Buna-N	2
568-356 O-Ring CMPD F-7001	1	912-8000-500	2
Model 20, 25, 32 Wood Clamp		2-261 O-Ring 90 Duro	1
Kit #221022	Quantity	Model 196 Sheet Clamp	
568-246 O-Ring N70	1	Kit #810473	Quantity
80-246 Contoured Backup	2	568-261 N90	1
250-04.500-375B-PO Lubrithane Polyseal	1	Wear Ring 612-1000-050	2
80-363 Contoured Backup	1	Wear Ring 612-725-050	1
568-363 O-Ring N70	1	PS1850-160 Bronze PT	1
Wear Ring 612-700-100	2	TP-069 T-Seal Buna/N	2
Wear Ring 8000-76E	2	TR-056 T-Seal, 2 Backups	1
AN-41-SH Urethane AN Wiper	1		
TFE-R-7000 Teflon	1		

Model 50, 150 Sheet Clamps		Model 100 Caisson Clamp	
Kit #1007377	Quantity	Kit #1007378	Quantity
SHCS 1.25"-12x4.0" Long	8	HCLW 1.25"	8
HCLW 1.25"	8	SHCS 5/8-11x4.0" Long	2
SHCS 1.0"-8x9.0" Long	2	HCLW 5/8"	2
HCLW 1.0"	6	SHCS 1.25-12x4.0" Long	8
SHCS 1.0"-8x3.0" Long	4	Grease-zerk, Straight 1/8" NPT	5
SHCS 1.5"-6x3.5" Long	8	Model 80 Caisson Clamp	
HCLW 1.5"	8		Quantity
Grease-zerk, Straight 1/8" NPT	1	SHCS 5/8-11x2.75" Long	2
SHCS 5/8-18x1.0" Long	12	H.S. Flat Washer 1.25"	4
Model 200 Sheet Clamp		Grease-zerk, Straight 1/8" NPT	3
	Quantity	SHCS 1/2-13x1.25" Long	2
SHCS 1.5-6x3.5" Long	10	HCLW 1/2"	4
HCLW 1.5"	10	SHCS 1.0-8x4.0" Long	8
SHCS 1.25-12x4.0" Long	8	HCLW 1.0"	8
HCLW 1.25"	8	SHCS 1/2-13x1.5" Long	2
SHCS 1.0-8x3.0" Long	4	Pointed Set Screw 1/2-13x1.0"	1
SHCS 1.0-8x9.0" Long	2	Model 200 Caisson	
HCLW 1.0"	6		Quantity
Grease-zerk, Straight 1/8" NPT	1	Kit #1007379	
SHCS 5/8-18x1.0" Long	12	SHCS 1.25-12x4.0" Long	8
Model 400 Sheet Clamp		HCLW 1.25"	8
	Quantity	SHCS 0.625-11x4.25" Long	2
SHCS 5/8-18x1.75" Long	15	HCLW 0.625"	2
SHCS 1.0-18x5.0" Long	30	Grease-zerk, Straight 1/8" NPT	7
HCLW 1.0"	40	Model 20 Sheet Clamp	
SHCS 1.0-8x11.0" Long	2		Quantity
SHCS 1.0-8x3.0" Long	8	SHCS 1.0-8x3.0" Long	14
Jaw Pin	1	SHCS 1.0-8x9.0" Long	2
Grease-zerk, Straight 1/8" NPT	1	HCLW 1.0"	16
		SHCS 1/2-13x5.5" Long	12

Bolt Kits

Torque and Tension Requirements

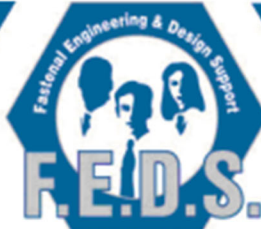

Torque-Tension Relationship for ASTM A574 Socket Head Cap Screws

Nominal Dia (in.)	Unified Coarse Thread Series						Fine Thread Series					
	threads per inch	Tensile Stress Area (sq. in.)	Clamp Load (lbs)	Tightening Torque			threads per inch	Tensile Stress Area (sq. in.)	Clamp Load (lbs)	Tightening Torque		
				K = 0.15 (ft-lbs)	K = 0.16 (ft-lbs)	K = 0.20 (ft-lbs)				K = 0.15 (ft-lbs)	K = 0.16 (ft-lbs)	K = 0.20 (ft-lbs)
1/4	20	0.0318	3341	10	11	14	28	0.0364	3819	12	13	16
5/16	18	0.0524	5505	22	23	29	24	0.0581	6097	24	25	32
3/8	16	0.0775	8136	38	41	51	24	0.0878	9222	43	46	58
7/16	14	0.1063	11162	61	65	81	20	0.1187	12465	68	73	91
1/2	13	0.1419	14899	93	99	124	20	0.1600	16795	105	112	140
5/8	11	0.2260	22883	179	191	238	18	0.2560	25916	202	216	270
3/4	10	0.3345	33864	317	339	423	16	0.3730	37762	354	378	472
7/8	9	0.4617	46751	511	545	682	14	0.5095	51584	564	602	752
1	8	0.6057	61332	767	818	1022	14	0.6799	68839	860	918	1147
1 1/8	7	0.7633	77282	1087	1159	1449						
1 1/4	7	0.9691	98123	1533	1635	2044						
1 3/8	6	1.1549	116932	2010	2144	2680	12	1.0729	108636	1697	1811	2263
1 1/2	6	1.4053	142282	2668	2846	3557	12	1.3147	133115	2288	2440	3051
1 3/4	5	1.8995	192320	4207	4487	5609	12	1.5810	160079	3001	3202	4002
2	4.5	2.4982	252945	6324	6745	8432						

Clamp load calculated as 75% of the proof load for socket head cap screws as specified in ASTM A574.

Torque values calculated from formula $T=KDF$, where

K = 0.15 for "lubricated" conditions, K = 0.16 "as-received" and K = 0.20 for "dry" conditions

D = Nominal Diameter

F = Clamp Load

UNDERSTANDING ISO CODES

The ISO cleanliness code is used to quantify particulate contamination levels per milliliter of fluid at 3 sizes 4µ[c], 6µ[c], and 14µ[c]. The ISO code is expressed in 3 numbers (ie 19/17/14). Each number represents a contaminant level code for the correlating particle size. The code includes all particles of the specified size and larger. It is important to note that each time a code increases the quantity range of particles is doubling.

ISO 4406 Chart		
Range Code	Particles per milliliter	
	More than	Up to/including
24	80000	160000
23	40000	80000
22	20000	40000
21	10000	20000
20	5000	10000
19	2500	5000
18	1300	2500
17	640	1300
16	320	640
15	160	320
14	80	160
13	40	80
12	20	40
11	10	20
10	5	10
9	2.5	5
8	1.3	2.5
7	0.64	1.3
6	0.32	0.64

Sample 1 (see photo 1)

Particle Size	Particles per ml*	ISO 4406 Code range	ISO Code
4µ[c]	151773	80000~160000	24
6µ[c]	38363	20000~40000	22
10µ[c]	8229		
14µ[c]	3339	2500~5000	19
21µ[c]	1048		
38µ[c]	112		

Sample 2 (see photo 2)

Particle Size	Particles per ml*	ISO 4406 Code range	ISO Code
4µ[c]	492	320 ~ 640	16
6µ[c]	149	80 ~ 160	14
10µ[c]	41		
14µ[c]	15	10 ~ 20	11
21µ[c]	5		
38µ[c]	1		

Photo 1

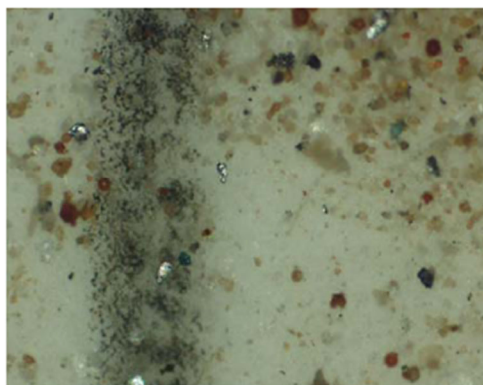

Photo 2



TARGET ISO CLEANLINESS CODES

When setting target ISO fluid cleanliness codes for hydraulic and lubrication systems it is important keep in mind the objectives to be achieved. Maximizing equipment reliability and safety, minimizing repair and replacement costs, extending useful fluid life, satisfying warranty requirements, and minimizing production down-time are attainable goals. Once a target ISO cleanliness code is set following a progression of steps to achieve that target, monitor it, and maintain it justifiable rewards will be yours.

Set the Target.
The first step in identifying a target ISO code for a system is to identify the most sensitive on an individual system, or the most sensitive component supplied by a central reservoir. If a central reservoir supplies several systems the overall cleanliness must be maintained, or the most sensitive component must be protected by filtration that cleans the fluid to the target before reaching that component.

Other Considerations
Table 1 recommends conservative target ISO cleanliness codes based on a several component manufacturers guidelines and extensive field studies for standard industrial operating conditions in systems using petroleum based fluids. If a non-petroleum based fluid is used (i.e. water glycol) the target ISO code should be set one value lower for each size (4 μ[c]/6μ[c]/14μ[c]). If a combination of the following conditions exists in the system the target ISO code should also be set one value lower:

- Component is critical to safety or overall system reliability.
- Frequent cold start.
- Excessive shock or vibration.
- Other Severe operation conditions.

Recommended* Target ISO Cleanliness Codes and media selection for systems using petroleum based fluids per ISO4406:1999 for particle sizes 4μ[c] / 6μ[c] / 14μ[c]

	Pressure	Media	Pressure	Media	Pressure	Media
	< 140 bar	βx[c] = 1000	212 bar	βx[c] = 1000	> 212 bar	βx[c] = 1000
	< 2000 psi	(βx = 200)	3000 psi	(βx = 200)	> 3000 psi	(βx = 200)
Pumps						
Fixed Gear	20/18/15	22μ[c] (25 μ)	19/17/15	12μ[c] (12 μ)	-	-
Fixed Piston	19/17/14	12μ[c] (12 μ)	18/16/13	12μ[c] (12 μ)	17/15/12	7μ[c] (6 μ)
Fixed Vane	20/18/15	22μ[c] (25 μ)	19/17/14	12μ[c] (12 μ)	18/16/13	12μ[c] (12 μ)
Variable Piston	18/16/13	7μ[c] (6 μ)	17/15/13	5μ[c] (3 μ)	16/14/12	7μ[c] (6 μ)
Variable Vane	18/16/13	7μ[c] (6 μ)	17/15/12	5μ[c] (3 μ)	-	-
Valves						
Cartridge	18/16/13	12μ[c] (12 μ)	17/15/12	7μ[c] (6 μ)	17/15/12	7μ[c] (6 μ)
Check Valve	20/18/15	22μ[c] (25 μ)	20/18/15	22μ[c] (25 μ)	19/17/14	12μ[c] (12 μ)
Directional (solenoid)	20/18/15	22μ[c] (25 μ)	19/17/14	12μ[c] (12 μ)	18/16/13	12μ[c] (12 μ)
Flow Control	19/17/14	12μ[c] (12 μ)	18/16/13	12μ[c] (12 μ)	18/16/13	12μ[c] (12 μ)
Pressure Control (modulating)	19/17/14	12μ[c] (12 μ)	18/16/13	12μ[c] (12 μ)	17/15/12	7μ[c] (6 μ)
Proportional Cartridge Valve	17/15/12	7μ[c] (6 μ)	17/15/12	7μ[c] (6 μ)	16/14/11	5μ[c] (3 μ)
Proportional Directional	17/15/12	7μ[c] (6 μ)	17/15/12	7μ[c] (6 μ)	16/14/11	5μ[c] (3 μ)
Proportional Flow Control	17/15/12	7μ[c] (6 μ)	17/15/12	7μ[c] (6 μ)	16/14/11	5μ[c] (3 μ)
Proportional Pressure Control	17/15/12	7μ[c] (6 μ)	17/15/12	7μ[c] (6 μ)	16/14/11	5μ[c] (3 μ)
Servo Valve	16/14/11	7μ[c] (6 μ)	16/14/11	5μ[c] (3 μ)	15/13/10	5μ[c] (3 μ)
Bearings						
Ball Bearing	15/13/10	5μ[c] (3 μ)	-	-	-	-
Gearbox (industrial)	17/16/13	12μ[c] (12 μ)	-	-	-	-
Journal Bearing (high speed)	17/15/12	7μ[c] (6 μ)	-	-	-	-
Journal Bearing (low speed)	17/15/12	7μ[c] (6 μ)	-	-	-	-
Roller Bearing	16/14/11	7μ[c] (6 μ)	-	-	-	-
Actuators						
Cylinders	17/15/12	7μ[c] (6 μ)	16/14/11	5μ[c] (3 μ)	15/13/10	5μ[c] (3 μ)
Vane Motors	20/18/15	22μ[c] (25 μ)	19/17/14	12μ[c] (12 μ)	18/16/13	12μ[c] (12 μ)
Axial Piston Motors	19/17/14	12μ[c] (12 μ)	18/16/13	12μ[c] (12 μ)	17/15/12	7μ[c] (6 μ)
Gear Motors	20/18/14	22μ[c] (25 μ)	19/17/13	12μ[c] (12 μ)	18/16/13	12μ[c] (12 μ)
Radial Piston Motors	20/18/15	22μ[c] (25 μ)	19/17/14	12μ[c] (12 μ)	18/16/13	12μ[c] (12 μ)
Test Stands, Hydrostatic						
Test Stands	15/13/10	5μ[c] (3 μ)	15/13/10	5μ[c] (3 μ)	15/13/10	5μ[c] (3 μ)
Hydrostatic Transmissions	17/15/13	7μ[c] (6 μ)	16/14/11	5μ[c] (3 μ)	16/14/11	5μ[c] (3 μ)

*Depending upon system volume and severity of operating conditions a combination of filters with varying degrees of filtration efficiency might be required (i.e. pressure, return, and off-line filters) to achieve and maintain the desired fluid cleanliness.

Example	ISO Code	Comments
Operating Pressure	156 bar, 2200 psi	
Most Sensitive Component	Directional Solenoid	19/17/14 recommended baseline ISO Code
Fluid Type	Water Glycol	18/16/13 Adjust down one class
Operating Conditions	Remote location, repair difficult	Adjust down one class, combination
	High Ingression rate	17/15/12 of critical nature, severe conditions

REFERENCE / NOTES

All information given in this manual is current and valid per the information available at the time of publication. Please check the updated revision date.

American Piledriving Equipment (APE) reserves the right to implement changes without prior notice.

Please visit for the most recent version of this publication.

AMERICAN PILEDRIVING EQUIPMENT, INC.

7032 S. 196th Street

Kent, Washington 98032

Office: 253-872-0141

Toll Free: 800-248-8498

Fax: 253-872-8710